

25 March 2013

Dr Eng. Jan Pająk

"Web pages of Jan Pająk - [explain.pdf](#)"

(i.e. a PDF brochure with the content of web page named [explain.htm](#) and entitled "How the 'Theory of Magnocraft' interprets UFO photographs")

Wellington, New Zealand, 2013,
ISBN 978-1-877458-69-9.

Copyright © 2013 by Dr Eng. Jan Pająk.

All rights reserved. No part of this brochure may be reproduced, stored in a database or retrieval system, transmitted, or distributed in any form or by any means, electronic, mechanical, photocopying, recording, or otherwise, without the prior written permission from the author or a person legally authorized to act on his behalf. From the obligation of getting such a written permission are only released those who would like to prepare a single copy of this monograph for their personal use oriented towards the increase of their knowledge and who fulfil the condition that they will not use the copy prepared for any professional purpose or for accomplishing material gains, and also that they copy the entire brochure - including the title page, all items, all illustrations, and all enclosures.

Date of the latest update of the web page presented in this brochure is provided above in the top-left corner. (Note that in case of having access to several copies of this brochure, it is recommended to read the copy which has the latest date of amendment.)

This PDF brochure publishes the text of the web page authored by Dr Eng. Jan Pająk, indicated in the title of it. In turn the author's web pages are forms of fast reporting to the readers results of scientific research accomplished by the author of this brochure. The author is aware, that this research, and the results, are unique, as no-one in the entire world undertook earlier research of topics elaborated in this brochure. Therefore ideas which this brochure presents are the intellectual property of the author of this brochure. All ideas, theories, inventions, discoveries, explanations, descriptions, etc., published here, which have documentary or evidential value, are presented accordingly to standards applicable for scientific publications (reports). A special attention the author has given to the requirement of repetitiveness, i.e. that on the basis of this brochure any professional scientist or hobby investigator who would like to verify, repeat, or extend the author's research should be able to recreate his work and arrive at the same or very similar results and conclusions.

This brochure is another one from a series of similar brochures in PDF, offered free of charges to interested readers through the totaliztic web page named [text 11.htm](#) - which disseminates PDF versions of most significant and most widely read web pages by the author. The topic of this brochure is represented also in the newest [monograph \[1/5\]](#) with following editorial details:

Pająk J.: "Advanced Magnetic Devices",
Monograph, Wellington, New Zealand, 2007, 5th edition,
in 18 volumes, ISBN 978-1-877458-01-9.

Contact addresses to the author valid in 2013 – i.e. during the preparation of this brochure:

[Dr Eng. Jan Pająk](#)

P.O. Box 33250, Petone 5046, NEW ZEALAND

Email: janpajak@gmail.com

One amongst numerous reasons for which the human science is so hopeless in UFO research, is that the objective photographs of these highly advanced interstellar spaceship record hundreds of different shapes and pictures which almost never represent the standard appearance of the silver discoidal starship which are commonly described as UFOs. Thus scientists and people who look at these photographs are NOT able to find in them any rule, consistency, nor sense. However, this consistency and sense do exist in there - we just need to learn how to find these and how to interpret the photographs. After all, if present jet passenger airliners were sighted in the medieval times, the witnesses then would also NOT be able to see any sense in them. This is because at one time the planes would be similar to silver birds, while another time they would just be white lines on the blue sky. In turn at nights someone would one time see them as rows of glowing windows, while another time - as fire blasting from their jet outlets. Similarly is with the authentic photographs of UFOs. On each occasion these photographs record different aspects and views of these

interstellar vehicles. This is why this web page presents scientific explanations as to what exactly show different classes of authentic UFO photographs, examples of the majority of which are interpreted here.

Part #A: Introductory information of this web page:

#A1. What are goals of this web page:

Motto: "Everything that affects us has a rational explanation - we just need to earn the correct explanation of it."

This web page places for itself several ambitious goals. The most vital of these is to present scientific interpretations for authentic photographs of UFOs, which (the interpretations) are based on the so-called "[Theory of the Magnocraft](#)". (The "Theory of the Magnocraft" is simply a theory which describes in details the interstellar spaceship which I had the honour to invent, the principle of operation of which is described under the name of the [Magnocraft](#). More information about the Magnocraft is presented in part #B of this web page.) Expressing this goal in other words, due to the knowledge about my "Magnocraft", on this web page I am able to explain scientifically what exactly present the authentic photographs of UFOs illustrated below, how these photographs were formed, and what one should especially notice in them.

Another vital goals of this web page is to document the consistence in the existing photographs of UFOs. Means, to prove on the example of authentic photographs of UFOs that the entire range of various shapes and phenomena, which is captured in completely different parts of the world and by completely different people that do NOT know about each other, always show the same kind of interstellar spaceships, only that photographed from different sides, in different lighting conditions, during different modes of operation, in different conventions and ways of flying, etc., etc. This in turn confirms again that all these consistent UFO photographs in fact register really existing starships - only that these starships intentionally and in an intelligent manner hide from people and openly scoff at the conceit of professional employees of present the so-called "**atheistic orthodox science**" (i.e. that official, although fundamentally wrong science,

which I described in details in items #C1 to #C6 from the web page named [telekinetics.htm](#)).

Still another goal of this web page is to complement with additional photographs this voluminous body of evidence that is used for logical construction of the **formal scientific proof which states that "UFOs do exists"** and which is presented, amongst others, on the totaliztic web page [ufo proof.htm - about the formal scientific proof that "UFOs are Magnocraft that were already constructed by some other civilisation"](#). Means proving that photographs shown as the evidence for this formal proof for the existence of UFOs are practically just a small droplet in the entire ocean of consistent photographic documentation for the existence of UFOs and for the continuous (although well hidden and intangible for ignorants) activity of UFOonauts on the Earth.

Further goals of this web page are to extend the photographic evidence for the existence of UFOs which is shown on the totaliztic web page [evidence.htm - about material evidence of the secretive activities of UFOonauts on the Earth](#). Means, to complement the entire range of various evidence for the existence of UFOs that is presented on that web page, by numerous photographs which document the appearance and the operation of UFO vehicles.

Part #B: The starship called the Magnocraft - means the basis and the key for providing scientific interpretation of UFO photographs and for full understanding of all UFO mysteries:

#B1. What is this Magnocraft:

The name Magnocraft is assigned to an interstellar spaceship (of my own invention) which for flights utilises various attributes of magnetic fields. Magnocraft is fully Earthly design - means it was invented and worked out completely on the Earth. The Magnocraft is described on a number of web pages - therefore here its detailed description is NOT going to be repeated. Readers wishing to get familiar with the design and operation of the Magnocraft can find the required information on the totaliztic web pages: [propulsion.htm - about regularities in the construction of Earthly propulsion systems, which allowed for inventing the Magnocraft](#), [magnocraft.htm - about the design and operation of the Magnocraft](#), or [oscillatory chamber.htm - about](#)

#B2. The formal scientific proof stating that the "interstellar spaceships known under the name of 'UFOs', are actually Magnocrafts that were already constructed by some other civilisations":

Motto: "The fast progress of knowledge and technology in past was accomplished because old-time scientists used to add new findings to scientific foundations created by their predecessors. In turn present stagnation in science and the lack of breakthrough technical accomplishments result from the fact that today scientists instead of adding, prefer to destroy solid foundations which were created by their predecessors. The most clearly this process of destruction of foundations is visible on examples of present research on UFOs and on reactions of today scientists to the formal scientific proof for the existence of UFOs."

The Magnocraft is the fully Earthly invention. Means it was completely invented, worked out, and one day will be build, on the Earth. But rules and physical laws that govern the development of new propulsion systems cause that since this starship could be invented on the Earth, it could also be invented on planets other than our one. Therefore inhabitants of these other planets arrive to the Earth in starships which are identical to the Magnocrafts. From this principle results the formal scientific proof stating that **"UFOs do exist and are Magnocrafts that were already constructed by some other civilisations"**. This proof is presented on the separate web page [ufo_proof.htm - about the formal scientific proof that "UFOs are Magnocraft that were already constructed by some other civilisation"](#). I recommend to have a look at that web page.

#B3. The postulate of interchangeability between UFOs and the Magnocrafts:

On a separate web page [ufo_proof.htm - about the formal scientific proof that "UFOs are Magnocrafts that were already constructed by some other civilisations"](#) it was proven conclusively that "the interstellar spaceships known under the popular name of UFOs are Magnocrafts already constructed by some other civilisations". In turn the consequence of this formal proof is the

principle that every correct equation, principle and fact established for the **Magnocrafts** must also apply to UFOs; as well as every fact observed on UFOs must apply to the **Magnocrafts**. This principle is known under the name **postulate of interchangeability between UFOs and the Magnocrafts**. This postulate is described in more details in item #D1 of the web page [ufo_proof.htm - about the formal scientific proof that "UFOs are Magnocrafts that were already constructed by some other civilisations"](#). The consequence of it is, amongst others, that presently we can scientifically interpret photographs of UFOs on the basis of our knowledge about the "**Theory of the Magnocraft**".

It should be added here that because of this "postulate of interchangeability between UFOs and the Magnocraft", every researcher of UFOs has almost a duty to learn the exact design and operation of the **Magnocrafts**. After all, when he or she learns thoroughly about the Magnocrafts, he or she also is going to know about UFOs the same well. This in turn is going to allow him or her to not only understand and to interpret the photographs and sightings of UFOs - as this is presented on this web page, but also it gives the more scientific character to his or her research on UFOs. As this web page is illustrating it, the knowledge of Magnocrafts is immensely helpful and useful in our learning the secrets of UFOs.

#B4. Sources of this extraordinary variation of shapes and appearances registered on photographs of UFOs: namely three "generations" of UFOs, three so-called "conventions of operation" of UFOs, three "modes of operation" of UFO propulsion systems in each of these conventions, eight "types" of UFOs, countless number of various "configurations" into which several UFOs can magnetically couple with each other, day and night photographs of UFOs, various parameters of photographing, and many more (all these explained on the

basis of the "Theory of the Magnocraft"):

Motto: "Everyone can criticise and deny, but only very few are able to create and to explain. In spite of this, in our civilisation criticising and denying is rewarded, while creating and explaining is punished."

These readers who ever photographed a UFO vehicle, know perfectly well the feeling of frustration. They personally saw a characteristic outline of a silver disk in the sky, which they knew from stories to be a UFO vehicle. They pointed a camera at it and shot a photograph. However, then it turned out that captured on a photo were just strange shadows and strands of light. No one believes that they actually saw and photographed an extraterrestrial UFO. So-called "sceptics" used this opportunity to scoff at them openly, claiming that they must be very drunk to take a balloon or a natural phenomena for an extraterrestrial UFO vehicle. The final outcome is such that the former UFO photographers close themselves and make a solemn promise to themselves that NEVER again are going to photograph anything that is non-typical, and also that they will tell no-one about any extraordinary thing that they may see accidentally.

Let us return to these shadows and strands of light which UFO photographers typically capture. Have these captured shapes really nothing to do with the silvery discs of extraterrestrial UFO vehicles which the photographers see with their own eyes? The objective answer is YES, these shapes have everything to do with UFOs. In fact the shadows, strands, and patches of light represent the same UFO vehicles that the photographers saw, only that perceived and recorded with a "technological eye" - which every camera is. In turn this "technological eye" works on completely different principle than real human eye. Thus, such "technological eye" sees some objects, including UFO vehicles, completely different than these objects are seen by a human eye. (How different can be the appearance perceived by the camera lens, each one of us can check this by taking a photograph of himself or herself in a street automat for passport photos, and then comparing the photograph received, with his or her own reflection in a mirror - this is why most of us on the passport photographs look like "escapees from a prison". We can also consider photographs of bullets - cameras can see and capture these, but human eyes are unable to do so.) There is a whole array of reasons for these differences between the sighted and photographed UFOs. Let us list here and describe at least these most important ones amongst such reasons.

1. Lights and glows induced by the propelling devices of UFO vehicles. The UFO propulsion systems work on electromagnetic principles. Thus, the propulsion systems of these vehicles are able to induce a whole range of subtle lights and glows, many of which remains invisible to human eyes - but are registered on photographs and on videos. Because photographs and video films keep enhancing the power of such lighting phenomena in relationship how these phenomena are perceived by human eyes, on photographs these lights and glows overcome all other shapes which in human eyes define what UFO vehicles are for us.

2. The huge variety of principles of operation which UFO vehicles

utilise in flights. If we show to some medieval monks our present airplanes and helicopters, the monks would also be unable to make a sense from whatever they see. This is because e.g. how to compare jet planes with propeller planes and with helicopters. A similar problem is with UFO vehicles. UFOs are NOT just a single kind of starship, but a huge variety of different sizes, designs, shapes, principles of operations, etc. In fact UFOs are constructed in as many as three different "generations". Each of these generations is composed of several drastically different designs, such as the "discoidal vehicles", "four-propulsor vehicles", "personal propulsion systems", and "tractor beams". Also each of these generations can fly in one, or in two, or in even three so-called "conventions of flight". In turn these "conventions of flights" of UFO vehicles differ between each other much more than the present jet airplanes differ from the present propeller airplanes. In addition to this, in each of these three "conventions of flight" the UFO propulsion system can work in at least three different so-called "modes of operation". In turn these "modes of operation" of UFO vehicles induce much bigger differences in the appearance of the same UFO vehicle than for the present jets would cause the viewing e.g. night flights with working jet propulsion systems (i.e. with jets blasting fires) and night flights of jet airplanes with extinguished engines (i.e. jets flying on principles of gliders). To this we need to add, that there are eight different "types" of UFOs, while each one such type looks differently. Each out of these types can couple magnetically with similar types, or with different types, into a huge number of various flying "configurations" of UFOs. Furthermore, the magnetic propulsion system used in UFOs can be implemented in several different designs and forms, e.g. as a discoidal vehicle, as a four-propulsor vehicle, as personal propulsion system, and as the so-called "tractor beam". On photographs all these variations can generate completely different shapes, lighting and glowing phenomena, appearances, etc., etc. No wonder that neither present scientists, nor ordinary people, are able to make any sense from all these appearances, nor understand all of them. (Actually present scientists typically even do NOT try to make any sense in all these shapes, as the present official science is incompetent and unprepared to research intelligences other than human one, which (the intelligences) do not cooperate with scientists who try to research them - as this is explained more comprehensively in item #B1 of the totaliztic web page [ufo_proof.htm - with the formal scientific proof for the existence of UFOs](#), and also explained in the post number #151E to blogs of totalizm - addresses of which are provided in item #K3 of this web page.) Only the so-called "Theory of the Magnocraft", means the theory of the Earthly starship with the magnetic propulsion system explained on the separate web page [magnocraft.htm - about the "Theory of Magnocraft"](#) allows us to introduce the sense and understanding in these countless variations of shapes in photographed UFOs.

3. Action of a whole range of aggressive "vision distorting factors". These factors are listed and described comprehensively in item #J3 - below on this web page [explain.htm - about scientific interpretation of authentic photographs of UFOs](#). The action of these factors boils down to the distortion of shapes of UFOs perceived by our eyes and registered on photographs. A best example of these factors is the so-called "magnetic lens" that appears in practically every UFO. This lens induces optical consequences

which are similar to consequences that we would notice if we watch UFO vehicles either through an ordinary lens, or via a "curved mirror". Means this magnetic lens distorts UFO shapes, hides or defocuses various UFO features, and can even cause a complete disappearance of the entire UFO vehicle from our view. And we must remember that the "magnetic lens" is just a single one amongst a whole array of extremely aggressive "vision distorting factors" that are described below in item #J3 of this web page. In turn each one amongst these factors can distort the appearance of a UFO to a degree that is equal of that caused by the action of a magnetic lens. No wonder that when we photograph a UFO and then compare the outcome to shapes registered on other photographs of UFOs, such a huge number of various shapes and outlines is obtained, that so-far people were unable to find any sense in all of them.

Fortunately for us the "Theory of the Magnocraft", described, amongst others, in volume 3 of [monograph \[1/4\] - "Advanced Magnetic Devices"](#) and also summarised on the separate web page [magnocraft.htm - about the "Theory of the Magnocraft"](#), provided us with a key for decoding puzzles of this huge variation of shapes and appearances of UFOs registered on photographs and on films. Due to this key we now are able to interpret exactly what subsequent photographs and films of UFOs really captured. In turn these interpretations reassure us that all authentic photographs of UFOs are consistent with each other, means that all these photographs captured the same kinds of interstellar space vehicles with the magnetic propulsion system, only that the vehicles were photographed in various lightning conditions and in various views, when working in different conventions and modes of operation, etc., etc.

* * *

For use of readers, on this web page is documented that actually there is a high consistency and sense in this huge variety of shapes captured on photographs of UFOs. In this way the web page additionally proves that UFO vehicles are physical vehicles which have strictly defined design and operation, only that they are still too advanced to be understood by an average human scientist. (In fact, the knowledge about UFOs in a typical present scientist, can be compared to a knowledge about our present jet airplanes in a typical medieval monk mentioned before.) In order to document this sense and consistency in shapes registered on photographs of UFOs, this web page provides most representative amongst such photographs. Photographs shown here are so selected that they illustrate each one amongst most vital classes of situations in which these interstellar starship can be captured. For each amongst these photographs the web page provides also the scientific interpretation as to what this photograph actually shows according to the "Theory of the Magnocraft". Principles of carrying out such a scientific interpretation of UFO photographs are explained comprehensively in a separate [treatise \[4c\]](#) (available in Polish only) by Jan Pająk and Adam Wróbel, "Interpretacje zdjęć UFO w świetle Teorii Magnokraftu" (i.e. "Interpretations of UFO photographs in the light of the Theory of the Magnocraft"), Treatise, Timaru, New Zealand, 2002, ISBN 0-9583380-5-1. Free copies of treatise [4c] are available through this web page. The treatise [4c] contains an extended and more in-depth interpretation for a significant number of UFO photographs, some of which are shown also here. (Photographs that originate from treatise [4c] have here the symbol "4c" at the very beginning of

their physical name - e.g. "4c_b11_1_z.jpg". Treatise [4c] also provides sources of origins for a majority of these photographs.)

* * *

Some photographs shown on this web page were send to me by readers for the scientific interpretation according to the "Theory of the Magnocraft". Wherever I had the required information, I provided a source from which a given photograph originates (means also the information about the owner, or even a contact with the owner, of copyrights for a given photograph). In turn in cases when I do not know this source, I simply provided only the photograph, together with the scientific interpretation of it. But I would be obliged is these readers who know origins of photographs from sources unknown to me, write to me providing details as to where a given photograph appeared or who have taken it. This is because I would like to contact the authors. Thanks in advance.

Part #C: Interpretations of photographs of single discoidal UFO vehicles flying in the magnetic convention of operation:

#C1. What is this "magnetic convention of operation":

The name "magnetic convention of operation" is assigned to the principle of operation of UFOs and Magnocraft, in which these starship form propelling and stabilisation forces in the result of magnetic repulsion and attraction that occurs between propulsors of these vehicles, and the natural magnetic field that prevails in the surrounding of these spaceship. In the "magnetic convention of operation" are able to fly UFOs and Magnocraft of all possible generations, types, and designs. But in spite of that, this particular convention is NOT used frequently on the Earth because in it the UFO vehicles are well visible for people, while crews of these starship (i.e. UFOonauts) try to continually hide from people their presence and activities on the Earth. Therefore most frequently the "magnetic convention of operation" is used at nights when the majority of people sleeps and also in areas deprived of human population - where UFOonauts are not afraid that someone sees them.

The "magnetic convention of operation" (which allows to travel only through the space) must be clearly distinguished from the "telekinetic convention of operation" described in part #E of this web page (which allows UFO vehicles to disappear from the human sight), and also distinguished from the "time travel convention of operation" described in item #F of this web page (which allows

UFO vehicles to travel to the past or to the future). Comprehensive descriptions all possible "conventions of operation" in which can fly both all Magnocrafts as well as all UFOs, are presented in subsection M1.4 from volume 11 of the newest monograph [1/5], and also in subsection B3 from volume 2 of older monograph [1/4].

In this "magnetic convention of the operation" the utilisation of the magnetic field for propelling UFO vehicles introduces certain consequences for these starships. For example, it causes that (a) UFO starships must be build in the strictly defined manner, that (b) their shape and dimensions must be described by a set of equations that is relatively easy for defining, that (c) there are only 8 types of discoidal, crew carrying UFOs which are named as types K3, K4, K5, K6, K7, K8, K9 i K10, that (d) all phenomena which UFOs induce can be predicted exactly and described already on our present level of knowledge (after all, scientifically we learned already attributes and actions of magnetic fields), etc., etc. When we analyse these consequences scientifically, then already at our present level of knowledge it can be predicted that UFOs of the so-called "first generation" can work only in three different "modes of operation". These modes are called (1) the "throbbing mode", (2) the "magnetic whirl" mode of operation, and (3) the "magnetic lens" mode of operation. In each of these three modes of operation the same UFO vehicle is going to look completely different. This part #C of the web page illustrates how a typical single UFO vehicle looks like in each of these three modes of operation.

The outer diameter "D" of every UFO vehicles is strictly defined by the following equation $D = 0.5486 \cdot 2^K$ metres (i.e. the "outer diameter D" expressed in metres is equal to the unit of measure called the "cosmic cubit" that amounts to 0.5486 of the Earthly meter, multiplied by 2 to power "K".) Since we know this equation, and we know that $H = D/K$, it is easy to determine that the outer dimensions of, for example, UFO type K3, i.e. the one for which $K=3$, captured on the photograph from "Fig. #C2a", equals to: diameter $D = 4.39$ metres, height (base to top) $H = 1.46$ metres. In turn the number of permanent crew members for each UFO vehicle is "K" (one should not confuse the number "K" of permanent crew members with the number of passengers).

#C2. A single UFO vehicle, the propulsion system of which works in so-called throbbing mode of operation, photographed in daylight:

The "throbbing mode of operation" in UFOs and Magnocrafts, is the mode of work of their propulsion system, in which during the day one can see the true appearance of UFOs. This result from the fact that in such a mode of operation the magnetic field generated by UFO propulsion system does NOT induce any phenomena that would generate light, nor induce any electromagnetic

phenomena that would hide the true appearance of UFOs. Therefore the shell of UFOs is then perfectly visible. Simultaneously the UFO vehicle itself is safe and can be approached without any danger to the human health. The name "throbbing" for this mode of operation originates from the fact that the magnetic field of such UFOs that fly in this mode actually is "throbbing" like a human heart, means its amplitude and output is periodically shrinking and expanding like a heart.

It is worth to add here, that independently from the "throbbing mode of operation" described here, during the "magnetic convention of flights" UFOs and Magnocraft are able to fly also in so-called "magnetic whirl mode of operation" and "magnetic lens mode of operation" - which for single discoidal UFOs are illustrated in further items of this part #C. In the "magnetic whirl mode of operation" the force lines of UFO magnetic field spin (whirl) very rapidly around the body of the vehicle, thus forming a whole range of highly dangerous phenomena. For example these force lines ionise the air causing it to glow strongly. In turn the cloud of such glowing air hides the real appearance of the UFO vehicle. In turn in the "magnetic lens mode of operation" the UFO magnetic field is constant.

Here is how an authentic photograph of a UFO illustrates the appearance of these discoidal vehicles in the "throbbing mode of operation" of their propulsion system:



(a)

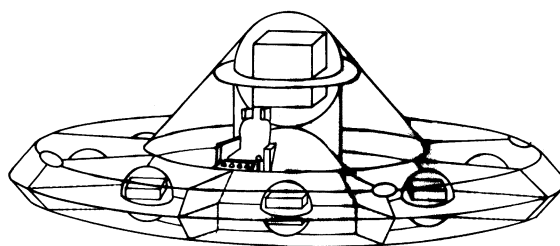

(b)

Fig. #C2ab: A photograph of a single discoidal UFO vehicle which flies in the so-called "throbbing mode of operation", photographed during daylight and in good lighting conditions. This kind of photographs reveal relatively clearly the appearance of the outer shell of UFO vehicles (although it does NOT eliminate completely the action of the so-called "magnetic lens"). Because the UFO shell is a kind of mirror with the regulated degree of reflection and transparency, such photographs clearly show the outer surface of the UFO vehicle, and thus also the external shape and appearance of the UFO. (Click on the above photograph or drawing to see it enlarged or to shift it to other area on the screen.)

Fig. #C2a (left): Here is a typical appearance of the UFO vehicle type K3, sighted in daylight from a side view in the "throbbing mode of operation" of its propulsion system. Perfectly visible becomes in it the glittering silvery (like a new

tin) outer shell of the crew cabin of this vehicle. This shell has this attribute, that it actually is a mirror with a controlled degree of light reflection and transparency. Thus, during the day the crew of this UFO can cause that this shell reflects light like a silver mirror. But during nights and in bad lighting conditions the crew of this UFO can make this shell to be completely transparent like a window. In such a case the crew can freely look at the surroundings of the vehicle, while outside witnesses can see exactly the interior of that UFO.

This photograph in 2001 was available for viewing on the web page free.eroskop.pl.

Fig. #C2b (right): My own drawing that illustrates a side view of the discoidal **Magnocraft** of the smallest type K3, shown in the "throbbing mode of operation" of its propulsion system, when its outer shell is controlled so that it is transparent for the light. In such a controlling of the shell, visible becomes also the internal design of this vehicle. The Magnocraft resembles an inverted saucer. Its propelling devices take the form of spherical "propulsors" which in Magnocraft of the first generation host cubical "twin-chamber capsules". The Magnocraft type K3 has a single lifting propulsor located in its centre, and eight stabilizing propulsors placed in its side flange, all nine of them loaded with magnetic energy. These propulsors are arranged like a parabolic mirror in a torch. Therefore an explosion of these propulsors would create a directional impact, similar to that formed by anti-tank cumulative charges. Because this vehicle always flies with its central axis parallel to the local course of Earth's magnetic field, its explosion must create a characteristic "butterfly" area of destruction, existing both in Tapanui and Tunguska UFO explosion sites. The ring-shaped crew cabin of this vehicle is assembled between the main propulsor and these eight side propulsors. One should notice that the side propulsors are assembled in the horizontal "separatory ring" placed at the top half of the flange which separates both magnetic poles (N and S) in each of these side propulsors, thus forcing the magnetic field which is produced to circulate through the environment. Each side propulsor is separated from other side propulsors by the eight "vertical partitions" which divide the vehicle's flange into eight separate chambers, each housing one side propulsor. The "shell of crew cabin", the "separatory ring", as well as the eight "vertical partitions", all these Magnocrafts' components are made of a special material that is impenetrable to the magnetic field, thus which protects the crew from the action of this field. Originally this is Figure F1(a) from monograph [1/4]. More comprehensive explanation of this Figure is provided on web pages [magnocraft.htm - about the "Theory of the Magnocraft"](#), and [\[1/4\] - about the monograph "Advanced Magnetic Devices"](#), listed in menus from the left margin of this web page.

* * *

Notice that you can see the **enlargement** of each illustration from this web site. For this, it suffices to **click** on this illustration. Furthermore, most of the internet browsers that you may use, including the popular "Internet Explorer", allow also to **download** each illustration to your own computer, where it can be looked at, reduced or enlarged to the size that you may want, or printed with your own graphical software.

If you wish to **shift** a given Figure (i.e. a photograph or a drawing), means to **move it into another part of the screen where you are just reading a**

description of it, you need to do as follows: (1) click on it to make it appear in another window, (2) the "downsize" this another window (with a given photograph or drawing) through "grabbing" its right-bottom corner with your mouse and then dragging this corner upwards-left to receive the size of this different window that you wish to have (notice that since you downsize a first such a Figure, all next Figures clicked on will appear already downsized - unless you enlarge them in the reversed manner), and then (3) drag this another window with the picture that you wish to relocate to the area of this web page where you wish to look at it (to move it, you just grab it with your mouse by the blue stripe on the top of it). Notice also that if you scroll (with scroll bars) the text of the page when you read it, this another window (with the drawing) will disappear. In order to return it into the new position, you need to click on its "icon" (i.e. on the "program's button" from the taskbar) in the lowest part of the screen.

#C3. The motionlessly hovering, or slowly flying, single UFO in the throbbing mode of operation photographed during a night:

During slow night flights in the "throbbing mode of operation" of their propulsion system, UFO vehicles do NOT form almost any spectacular lighting effects. After all the "throbbing" magnetic field of their propulsion system almost does NOT have the ability to induce electric currents and to ionise the air. Therefore the majority of the surface of such a night UFO remains black. In this way it blends with equally black sky. But exactly at outlets from propulsors of such a UFO, super-powerful magnetic field ionises small patches of the air. Furthermore, inside of propulsors of such a UFO, streams of rotating electric sparks from the so-called Oscillatory Chambers assembled in these propulsors, also emit light. Therefore, if propulsors of such a UFO are directed with their outlets towards a witness on the Earth, then this witness sees the light that they emit. Thus, when a slowly flying UFO is photographed, filmed, or sighted at night in the "throbbing mode of operation" of its propulsion system, it usually looks like a ring of lights which define locations of the side propulsors. Sometimes in the centre of this ring also is visible a single light from the main propulsor of that UFO. (If the so-called "magnetic lens" is working, this single light from the main propulsor sometimes may be apparently "shifted" in a slightly different place than it is positioned in reality.)

The exact explanation what are "side propulsors" and the "main propulsor", how many " $n = 4(K - 1)$ " side propulsors have subsequent types of Magnocrafts and UFOs, and also how looks like and what is this "Oscillatory Chamber", all this is described on web pages regarding the Magnocraft, and listed in the menu, e.g. on the web page [magnocraft.htm - about the "Theory of the Magnocraft"](#).

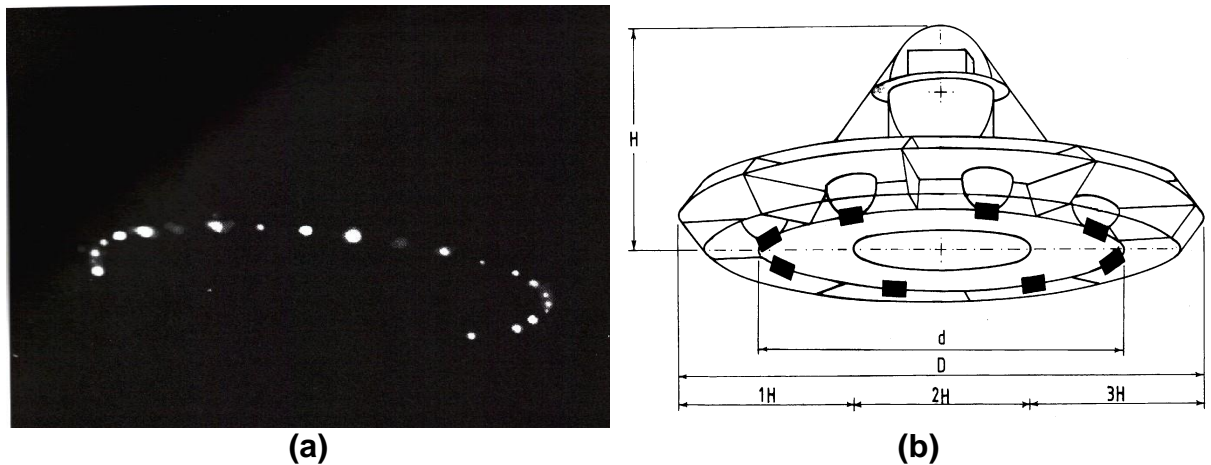

Fig. #C3ab: The appearance of a slowly flying UFO vehicle photographed at night in the "throbbing mode of operation" of its propulsion system. In this mode of operation on night photographs of slowly flying UFOs visible become only patches of the glowing air that is ionised at outlets from propulsors of this vehicle. The colour of these glowing patches depends on the magnetic pole N or S which ionises the air. For example, at outlets from N poles of propulsors of UFOs and Magnocrafts, the air is ionised in yellow or orange colours. In turn at outlets from S poles of propulsors, the air is ionised in colours green or blue. (Click on the above photograph or drawing to see it enlarged or to shift it to other area on the screen.)

Fig. #C3a (left): The appearance of a slowly flying UFO vehicle photographed at night on a black-white photograph during a throbbing mode of operation. In such mode of operation, and in the lack of external sources of light, in fact almost nothing is visible from this UFO. Thus the outside witness can only notice the glow of patches of the air ionised at outlets from propulsors of this vehicle, and the light from sparks that come out from so-called "Oscillatory Chambers" from propulsors of the vehicle (if outlets from these propulsors are directed towards the photographer). The above photograph shows 20 such glowing outlets from side propulsors of this UFO. But if we count also propulsors the glow of which was not captured on the photograph, but the existence of which is indicated by the uniform location of side propulsors, then it turns out that this UFO has "n = 32" side propulsors. Because there is a mathematical relationship between the number "n" of side propulsors of a given UFO vehicle, and the type factor "K" - this relationship takes the form " $n = 4(K-1)$ ", it is possible to determine easily, that the above photograph captured the UFO type K9 (for which "K=9", while "n=32"). The equations provided in item #C1 of this web page inform us that such a UFO of the K9 type has following outer dimensions: outer diameter $D = 280.88$ metres, height (base to top) $H = 31.21$ metres. Permanent crew of the UFO type K9 is composed of 9 UFOonauts.

Similar night photographs of a slowly flying UFO are shown in photographs "Fig. #C11ab" from item #C11 of the totaliztic web page [ufo proof.htm - about the formal scientific proof that "UFOs are Magnocraft that were already constructed by some other civilisation"](#).

Fig. #C3b (right): The drawing which shows the appearance of the Magnocraft type K3 in the "throbbing mode of operation", when the outer shell of it is controlled to be transparent. For such controls of the outer shell, if the light

allows it, the internal design of the starship is also visible. Unfortunately, if this starship is photographed at night, then the only things to remain visible, are patches of two-colour glow at outlets from propulsors - marked in black on the above drawing. The Figure shows also the most vital dimensions that allow to determine the **type** of a given starship. (How to determine this type it was explained in Figure #E1b from the web page [ufo_proof.htm - about the formal scientific proof that "UFO vehicles do exist"](#). Please notice that the lines that indicate the outer dimensions "D" and "H" of this starship, of course in real UFO sightings are NOT visible. Originally this drawing is shown as Figure F20 from monograph [1/4]. The more comprehensive explanation of this drawing is provided on web pages [magnocraft.htm - about Magnocrafts](#) available via menus from this web page.

The "type" of a UFO can be determined relatively easy through measuring for a given vehicle the so-called "type factor" marked by "K". This factor states how many times the outer height "H" (base to top) fits into the outer diameter "D" of a given starship, means $K = D/H$. For UFOs type K3 this factor amounts to $K=3$, for UFOs type K4 this $K=4$, etc. ..., until for the largest UFOs type K10 this factor "K" equals to $K=10$. The manner of measuring the "K" factor is illustrated in "Fig. #C3b". Notice that on this diagram is shown the Magnocraft type K3 (the same as on the "Fig. #C2"), i.e. the one for which $K=3$.

* * *

At this point it should be emphasized that if the outlets from UFO propulsors are viewed at night with naked eyes, or captured on colour photographs or colour film (not on the black-white as the above), then their glow has two clearly different colours, depending on the magnetic pole N, S directed towards the photographer. These colours of glow of UFO propulsors are described and documented on photographs in item #C11 of the web page [ufo_proof.htm - about the formal scientific proof that "UFO vehicles do exist"](#) (see in there "Fig. #C11ab").

#C4. Fast flying single UFO in the throbbing mode of operation photographed at night:

In fast flying UFO vehicles photographed at nights in the throbbing mode of operation, instead of patches of light at outlets from the propulsors, appears a whole chain of flashes of the air ionised by the magnetic circuits of that UFO that are directed towards the photographer. Such flashes were described and documented with photographs in item #C5 of the web page [ufo_proof.htm - about the formal scientific proof that "UFO vehicles do exist"](#) (see "Fig. #C5a" in there). Thus, these photographs are NOT going to be displayed and discussed again here ([click on this green writing in order to see here one of these photographs](#)).

#C5. A single UFO hovering in the air almost motionlessly in the magnetic whirl mode of operation photographed during the daylight:

In the "magnetic whirl mode of operation" force lines of the magnetic field generated by the propulsors of UFOs whirl extremely fast around the physical shell of the vehicle. In turn their whirling causes a powerful ionisation of the air. In this case the true physical shapes of a UFO are hidden behind a cloud of ionised and strongly glowing air.



Fig. #C5: The appearance of a UFO vehicle photographed in daytime in the "magnetic whirl mode of operation" (but with a small power of the magnetic whirl). In this mode typically on daytime photographs of UFOs visible becomes just only the glowing air that is ionised by the magnetic whirl created by the propulsion of these vehicles. This glowing air forms a picture called the "ionic picture of the whirl". The true shape of the UFO's shell hides inside of this "ionic picture of the whirl". (Click on the above photograph to see it enlarged or to shift it to other area on the screen.)

#C6. A single UFO which flies so fast in the magnetic whirl mode of operation, that human eyes are unable to notice its existence, photographed in daytime:

UFO vehicles (and also Magnocrafts) can fly in the air with high velocities that exceed even 60 000 km/h. Thus such UFOs can fly even faster than rifle

bullets. In such extremely fast flights human eyes are unable to notice them. But the photo-camera sometimes accidentally registers them. In such cases on the photograph the appearance of the UFO vehicle is hidden by waves of the air which the fast flying UFO induces with its flight. Here is an example of just such a photograph of the extremely fast flying UFO vehicle:

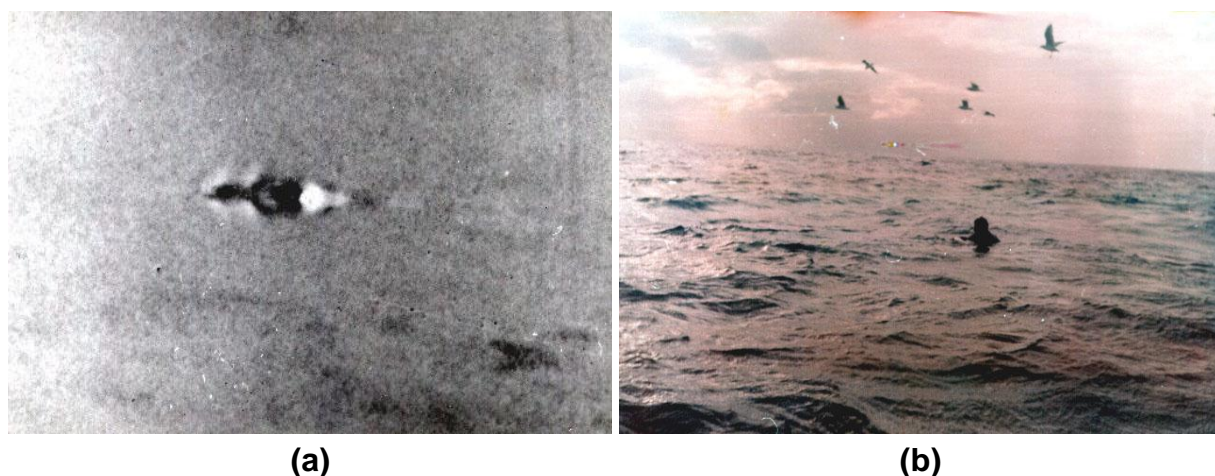

Fig. #C6ab: A UFO vehicle which flies even faster than a rifle bullet. (Click on the above photograph or drawing to see it enlarged or to shift it to other area on the screen.)

Fig. #C6a (left): The blow up of an extremely fast moving UFO. It was taken by Mrs Edwards B. of Devona Street, Aspley, Brisbane, Australia, on 12 May 1973. She took this photograph while on holiday when Mr Sinel (her friend) fell from a yacht into the water, approximately 6 km off the south east Bay of Mayor Island (Tuhua Rocks), New Zealand. After the film was developed, a vehicle unnoticed by witnesses at the time appeared to fly just above the horizon. The estimated speed of this UFO was about 60,000 kilometres per hour. On the next frame, taken a few seconds later, the vehicle did not appear.

Fig. #C6b (right): The entire frame on which this UFO vehicle that flies even faster than a rifle bullet was captured. The UFO vehicle can be seen just above the line of horizon, near the area where near the horizon like a front of a boat is visible above the head of the person floating the sea, but much below (and between) the group of four sea gulls.

#C7. A single UFO flying slowly or hovering motionlessly in the magnetic whirl mode of operation, photographed at night with a long time of exposure:

Night photographs of hovering or slowly moving UFOs can capture only the appearance of the cloud of the air strongly ionised by the whirling magnetic field of these UFOs. The cloud hides inside the physical appearance of these UFOs.

The ionised cloud is known under the name "ionic picture of a magnetic whirl". This picture in fact reflects the shape formed from force lines of magnetic field generated by the propulsion system of a given UFO, not the shape of the outer shell of the UFO itself.

The "ionic picture of the magnetic whirl" is also described and documented on photographs in item #C7 of the web page [ufo_proof.htm - about the formal scientific proof that "UFO vehicles do exist"](#) (see there "Fig. #C7ab").

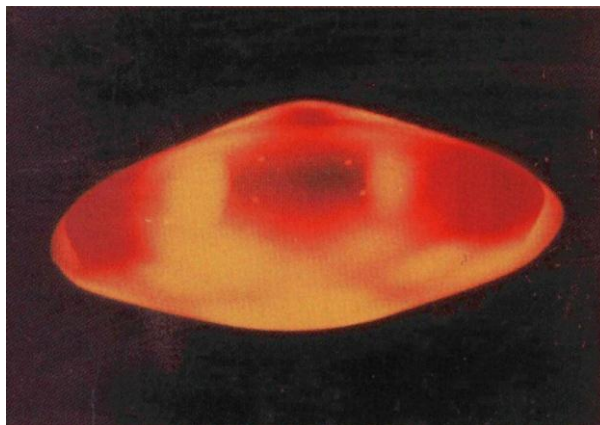

Fig. #C7: The appearance of the motionless or slowly flying UFO vehicle photographed at night in the "magnetic whirl mode of operation". In this mode, on night photographs of UFOs visible becomes just a powerful glow of the air ionised by the magnetic whirl of that UFO, and thus forming the so-called "ionic picture of the whirl". (Click on the above photograph to see it enlarged or to shift it to other area on the screen.)

It is worth to notice that in fast flying UFOs photographed at night, their ionic picture of the whirl is blown out of the typical shape. Thus, the forms of this picture that are registered then look much different (less symmetrical). An example of just such "disfigured ionic picture of the whirl" is shown on the photograph from "Fig. #C12ab" on the web page [ufo_proof.htm - about the formal scientific proof that "UFO vehicles do exist"](#).

#C8. A single UFO in the magnetic whirl mode of operation photographed at night with very short time of exposure:

In UFO vehicles photographed at night in the magnetic whirl mode of operation, when the photographing camera is set for a very short time of exposure, instead of a solid so-called "ionic picture of the whirl", the photograph shows a dynamic picture of spinning so-called "magnetic circuits of the UFO". Just such glowing magnetic circuits are described and documented on photographs in item #C4 of the web page [ufo_proof.htm - about the formal scientific proof that "UFO vehicles do exist"](#) (see there "Fig. #C4abc"). So these photographs are NOT going to be displayed and discussed here

again ([click on this green writing in order to see here one of these photographs](#)). Here, on this web page, the course of such "magnetic circuits" is visible on "Fig. #D8a" below.

#C9. A single UFO photographed from below in the magnetic lens mode of operation:

The so-called "magnetic lens" is simply a configuration of extremely powerful magnetic field of a UFO, that causes the bending of paths of light. The most strongly such a magnetic lens appears when UFO vehicles are wrapped into a constant magnetic field. In such cases it can even cause the complete disappearance of the UFO from our view. But the action of it to some degree is also unleashed in every other kind of magnetic field. Therefore a "magnetic lens" reveals its action practically on every photograph of a UFO. Because it changes the appearance of a UFO in a manner as if this appearance would be changed when we see the UFO in a "curved mirror", the magnetic lens sometimes deforms significantly the appearance of the UFO vehicle being photographed. But the most clearly it can be noticed in cases when UFO vehicles are just ascending, while someone looks at them (or photographs them) from the below - as this is shown in "Fig. #C9b" below. In such cases the "magnetic lens" causes the complete disappearance of the entire body of the UFO, means the disappearance of the entire part of the UFO which in "Fig. #C9b" below is marked with the dotted line. The only thing that then still remains in the view, is the square or rhomboidal outline of Oscillatory Chambers from the main propulsor of that UFO vehicle. (Notice that a "rhomboid" or a "diamond" is a square sighted from the direction of its corner.) More about this "magnetic lens" that always is unleashed in the ascending UFOs, is explained in subsection F10.1 from volume 3 of monograph [\[1/4\] - "Advanced Magnetic Devices"](#).



(a)

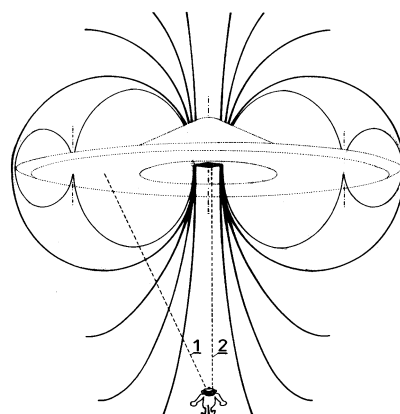

(b)

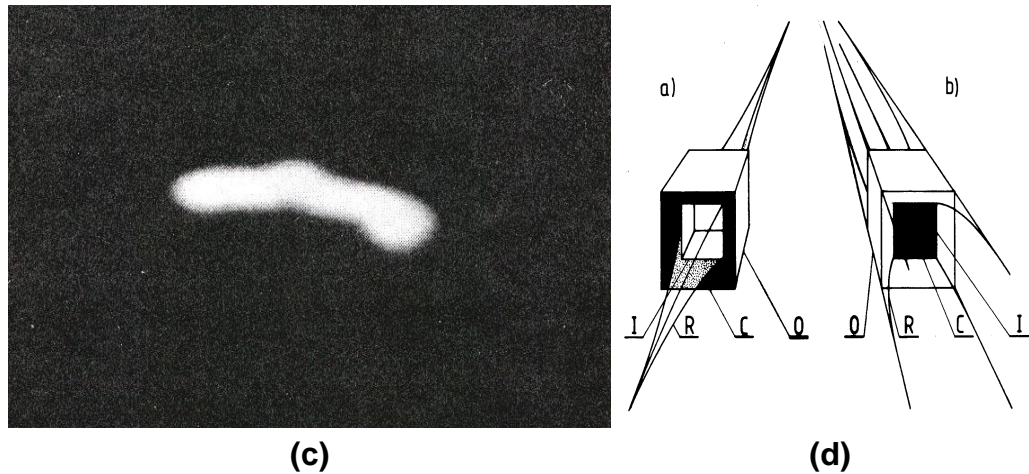

Fig. #C9abcd: A daytime and night-time appearance of a single UFO vehicle ascending upwards in the "magnetic lens mode of operation" and photographed from below. Both these photographs were taken in circumstances explained in part "b" of this illustration (i.e. explained in "Fig. #C9b"), when the photographer was able to register only outlines of the outlet from the square "twin-chamber capsule" composed of the main Oscillatory Chambers of that vehicle, while the remaining parts of the vehicle's shell remained invisible. (On the above photographs (a) and (c), outlines of this "twin-chamber capsule" look like sections of a "rhomboid", or "diamond", because they were captured from the direction of their corner, while their back parts were hidden behind a column of the non-transparent magnetic field that was yielded to the environment from a given "twin-chamber capsule".) Notice that in both above cases (a) and (c) the thickness of the space between the side edges of the outer "ao" and inner "ai" Oscillatory Chamber of a given "twin-chamber capsule" fulfils the equation (C9): $ao=ai(\sqrt{3})$. (Click on the above photographs or diagrams in order to see them enlarged, or to shift them into other parts of the screen.)

Fig. #C9a (top-left): One of the best colour photographs of a "twin chamber capsule" from the main propulsor of an ascending UFO, taken in daylight. The Oscillatory Chambers of the main propulsor in this UFO just work in the "mode of the domination of the inner flux". In such an ascending UFO the output from its main propulsor is so powerful, that it forms the "magnetic lens" which hides in itself the entire body of the UFO vehicle and allows to see just only the appearance of the "twin-chamber capsule" from the main propulsor of that UFO. (What is this "twin-chamber capsule", it is explained on the web page [oscillatory_chamber.htm - about the design and operation of "Oscillatory Chambers"](#).) The above photograph (a) was taken by a teacher in Hawaii and subsequently published in the book [3S1.3], "Into the Unknown", Reader's Digest, Sydney, Australia, 1982, ISBN 0 909486 92 1, page 315. On good quality copies of this photograph the cone of powerful magnetic field yielded to the environment by the inner Oscillatory Chamber of this UFO is clearly visible. This cone conceals the outlines of two back edges of the "twin-chamber capsule". (This is because of this cone of the powerful field, that instead of the entire "rhomboid", the photograph captured only two frontal sides of it - both back sides of this

"rhomboid" were hidden behind the cone of the magnetic field that is non-transparent for the light and that is yielded by this "twin-chamber capsule".) In the photographed twin-chamber capsule the so-called "resultant flux" is provided by the inner Oscillatory Chamber, whereas the entire output from the outer Oscillatory Chamber is drawn into the "circulating flux". The magnetic field bent by the outer Oscillatory Chamber into the "circulating flux" has a clearly distinguishable boundary and therefore acts as a trap for light known in optics under the name of a "black hole" (see also the description of "black bars" - in "Fig. #D4ab"). Thus, the inside of the outer chamber is visible as a blackened area. Because of the action of this "magnetic lens" in the photograph above the vehicle's main magnetic circuits dissipate the outer parts of the UFO shell - see also part "b" of this Figure (i.e. see "Fig. #C9b"). But because the central magnetic circuit radiates from this lens and forms a type of vision channel directed towards the photographer, the twin chamber capsule that produced this circuit remains clearly visible. (Originally the above photograph appears as Figure S5 (left) in monograph [1/4].)

Notice that the above photograph is also shown and discussed in item #E3 of the totalistic web page [propulsion.htm - about advanced magnetic propulsion systems for flying vehicles](#) (see "Fig. #10abcd" in there).

Fig. #C9b (top-right): The explanation for a "magnetic lens" effect produced by the central magnetic circuits of ascending Magnocrafts and UFOs. This effect means that an observer who watches such an ascending Magnocraft from below sees only a "twin chamber capsule" from the main propulsor, whereas the entire shell of the vehicle remains invisible to him or her (see also "Fig. #C9d"). This is because in the ascending Magnocrafts, the power of the magnetic field involved in the central magnetic circuit exceeds many times the power involved in the main and side circuits. Thus force lines of the central magnetic circuit hermetically surround not only the entire body of the vehicle, but also its main and side magnetic circuits. The extremely concentrated magnetic field from this central circuit interferes with light reflected to the observer. This interference manifests itself in the following two ways: (1) paths of light which pass across the field force lines are bent (i.e. the light reflected from the vehicle's body is deflected so that it does not reach the eye of an observer), but (2) light which passes along the field force lines is unaffected (i.e. the light reflected from the "twin-chamber capsule" reaches the eye of an observer). Therefore the observer, who watches such an ascending Magnocraft or UFO from below, can easily see a twin chamber capsule from the main propulsor, but he or she is unable to see all the other parts of the vehicle which are hermetically sealed in magnetic force lines. Symbols: 1 - path along which light is unable to pass through; 2 - unaffected path of light. (The above drawing originally is shown as Figure F32 in monograph [1/4].)

Please notice that more comprehensive explanation of this drawing is provided also in item #21 on the web page [magnocraft.htm - about the "Theory of the Magnocraft"](#).

Fig. #C9c (low-left): A night time photograph of the "twin chamber capsule" from an ascending UFO. It was taken by a newspaper reporter over Clovis, New Mexico, on January 23, 1976 - see page 49 of the book [5S1.1] by Joshua Strickland, "There are aliens on earth! Encounters", Grosset & Dunlop, New York,

1979, ISBN 0 448 15078 6. The illustrated capsule operates in the "mode of outer flux prevalence", the visual appearance of which is explained in part "d" of this Figure (i.e. in "Fig. #C9d-(b)"). In this mode the "resultant magnetic flux" is produced by the outer Oscillatory Chamber, whereas the entire output of the inner chamber is bound into the "circulating flux" - see the explanations in part "d" of this Figure. In this way the "resultant flux" yield to the environment must strongly ionize the air, thus in night photographs it appears as thick, glowing edge of an outer diamond. On the other hand the "circulating flux" must produce a black inner diamond, which because of the darkness, is not distinguishable from the similarly black background. Because of the orientation of the above capsule towards the photographer, two rear glowing edges of the outer diamond are hidden behind the non-transparent column of a magnetic field yield from the "twin-chamber capsule". Therefore the above picture reveals only two front glowing edges of the outlet from a twin chamber capsule which from a distance appears as a half diamond. (Originally this is Figure S5 from monograph [1/4].)

Fig. #C9d (low-right): The illustration of differences in visual appearance of "twin chamber capsules" of the first generation sighted ion both opposite modes of operation. Illustrated are twin-chamber capsules that operate in two opposite modes called: (a) the "INNER flux prevalence", and (b) the "OUTER flux prevalence". Because a strong magnetic field produced in both capsules is translucent only when observed along the field force lines, the curved force lines of "circulating flux (C)" are non-transparent to the outside observer and thus must be seen as "black bars" (these "black bars" are kinds of optical "black holes" for the light). (Originally this is Figure C6 from monograph [1/4].)

The left case (a) in the drawing of this "twin-chamber capsule" illustrates the operation of it in the "inner flux prevalence". The "resultant flux (R)" is produced here by the inner Oscillatory Chamber (I), whereas the entire output of the outer Oscillatory Chamber (O) is turned into the "circulating flux (C)" that is locked inside of the capsule. Therefore in this "twin-chamber capsule" the space between the inner and outer chamber is impenetrable to light and appears as a totally blackened area (i.e. the area that looks like a "black hole" in optics).

The right case (b) in the drawing of this "twin-chamber capsule" illustrates the operation of it in the "outer flux prevalence". The "resultant flux (R)" is produced here by the outer Oscillatory Chamber (O). The inner Oscillatory Chamber (I) supplies only the "circulating flux (C)" that entirely curves itself back into the outer Oscillatory Chamber. Therefore in this capsule the cross area of the inner Oscillatory Chamber is totally blackened (i.e. it looks like a "black hole" in optics).

* * *

The above photographs are also discussed (from a different point of view) in item #E3 (see "Fig. #10abcd" in there) of the web page [propulsion.htm - about advanced magnetic propulsion systems for flying vehicles](#).

#C10. A single UFO photographed at night from a large distance with non-typically

long time of exposure:

Such UFOs appear on photographs as long strands of light. Such strands are shown in item #1 of the totaliztic web page [shuttle.htm - about the downing of the space shuttle "Columbia" by UFOs](#) (see "Fig. 2" in there) - so here are NOT going to be displayed and discussed again ([click on this green writing in order to see here one of these strands](#)).

#C11. A single UFO photographed at night when its propulsors work as searchlights and beam a column of light to the Earth:

Such a UFO appears on photographs as a source of a single beam, or several beams, of extremely bright and slender light pointed towards the ground, that hovers somewhere in space (sometimes even in clouds). Just such columns of light beamed to the ground by UFO vehicles, are shown in item #A1 of the totaliztic web page [memorial.htm - how UFOonauts undermine the evidential value of authentic photographs of UFOs](#) (see "Fig. #1ab" and "Fig. #3" in there) - thus here are NOT going to be discussed and shown again ([click on this green writing in order to see here a photograph of such beams](#)).

At this point it should be added that such "columns of light" beamed to the ground from UFO propulsors fulfil several functions at once. Only one of these functions is to shone some light at the selected area of the ground which UFOonauts wish to examine more thoroughly. Other, much more frequently used function, is to use such a "column of light" as a kind of channel that directs the gip of the so-called "tractor beam". This "tractor beam" is simply a kind of like "lift formed from light". This "lift" is using the phenomenon of technically induced [telekinesis](#) to move selected objects, or move abducted people, or move members of UFO crews, between the surface of the Earth and the deck of a UFO vehicle. Thus, many people abducted to decks of UFOs, report later that they were lifted to a UFO, and sometimes also returned to the Earth, just with the aid of such beam of light. (Sometimes their return to the Earth is carried out on a different principle of [shifting their time back](#) - see in "timevehicle.htm" the description of so-called "one-way trip".)

#C12. A single UFO that hides from the human sight inside of a cloud that it forms technically around itself, photographed in

daylight:

Such a UFO on photographs appears as a non-typically regular white cloud - frequently of the hue slightly different from the remaining clouds on the sky. A photograph of just such "UFO-cloud" is shown in item #2 of the totaliztic web page [cloud_ufo.htm - about clouds that hide UFO vehicles inside](#) (see "Fig. 2" in there) - so here it is NOT going to be repeated and discussed again ([click on this green writing in order to see here a photograph of such UFO-cloud](#)).

#C13. Let us notice the number of the above different classes of pictures of just a single UFO - i.e. photographed was just one kind of a discoidal UFO vehicle, while we received so many different images of it:

In this part #C of the web page many different shapes were shown which are obtained on photographs of just a single discoidal UFO. But we must remember that this single UFO can later be coupled together with other UFOs thus forming a countless number of complex flying configurations of UFOs - as this is shown in the next "Part #D". In turn each one amongst these countless configurations can again form the described above, although already different, shapes and forms captured on photographs. In order to be even more interesting, all these must be then multiplied by three different generations of UFOs that operate in three different "conventions of flight", and then also multiply by numerous forms of the propulsion system that can be constructed in each amongst these three generations (such as discoidal UFOs, four-propulsor UFOs, personal propulsion systems, and so-called "tractor beams"). All these taken together mean that captured on UFO photographs can be almost infinite number of shapes of UFOs. However, all these countless shapes of UFOs display a very strict consistency which allows already now to unambiguously determine which UFO photographs are authentic, and which are "fakes" or "fabrications". (The faked photographs of UFOs are shown on the web page [memorial.htm - how UFOnavts undermine the evidential value of authentic photographs of UFOs](#) - see e.g. "Fig. #6b" in there).

Part #D: Interpretation of photographs of the entire flying configurations of UFOs

formed through magnetic coupling together several individual UFO vehicles that fly in the magnetic convention of flight:

#D1. What are these configurations of coupled UFO vehicles:

Flying configurations of UFO vehicles (or our Earthly Magnocrafts) are simply groups or teams of these vehicles coupled together with magnetic forces that originate from their propulsors. Such coupled groups of UFOs able to fly as a single unit controlled by one pilot. We could compare them to our trains in which instead of individual wagons UFO vehicles are magnetically joined together, or to our trucks which carry trailers.

In fact a practically unlimited number of various flying arrangements can be coupled together from UFOs or from Magnocrafts. But because of the manner in which subsequent vehicles are mutually joined in these configurations, we can distinguish 6 basic classes of these configurations. All 6 these flying arrangements of UFOs and Magnocrafts are illustrated in "Fig. #5abcdef" from the web page [propulsion.htm - about advanced magnetic propulsion systems for flying vehicles](#).

#D2. A spherical flying complex of UFOs:

A spherical flying complex of UFOs or Magnocrafts is formed when two such vehicles couple together magnetically with their floors. The external appearance of just such a "spherical flying complex" formed from two UFO vehicles of the K6 type is shown below in "Fig. #D2". In turn the principle of formation of such a "spherical flying complex" coupled together from two Magnocrafts of the K3 type (means the smallest crew-carrying type of these vehicles) is illustrated below in "Fig. #D2c".



(a)

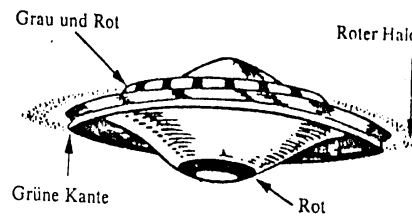

(b)

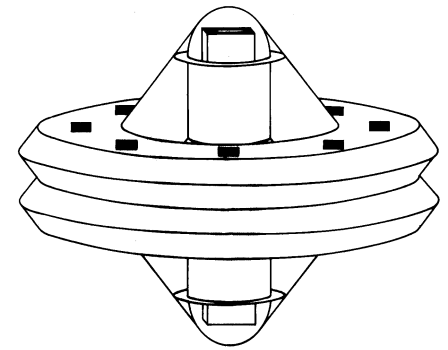

(c)

Fig. #D2abc: The comparison of spherical flying complex coupled together from two UFOs type K6 and photographed over Sweden by Lars Thorn on 6 May 1971, with the appearance and configuration of a spherical flying complex of two Magnocrafts type K3. (Click on the above photograph or drawings to see them enlarged or to shift them to other area on the screen.)

Fig. #D2a (left): This is the photograph of the most thoroughly investigated spherical complex of UFOs. This photograph was taken by a citizen of Sweden named Lars Thorn, on 6 May 1971. It shows a UFO type K6 hovering motionlessly on the background of local landscape. From my research it appears that a crew of such a UFO type K6 includes scientists specialised in geological research. (This is why landings of UFOs type K6 can be found near stones, interesting cracks of the soil, etc.) It is worth to notice that a UFO from this photograph also seems to be interested in nearby geological structures.

Fig. #D2b (middle): The reconstruction of the appearance and shape of this spherical complex of UFOs, prepared by the Stockholm investigating group named GICOFF. This reconstruction, together with the above photograph, is published on page 81 in the book [1P2] by Adolf Schneider and Hubert Malthaner: "Das Geheimnis der unbeakantnen Flugobjekte" Hermann Bauer Verlag KG - Freiburg im Breisgau, West Germany, 1976, ISBN 3 7626 0197 6. It very clearly reveals the double flange that fastens the resultant complex half way of its height. This flange is formed through coupling together the lens-shaped side flanges of both vehicles. In the lower vehicle, the outlet from the main propulsor is visible. In the upper vehicle four "black bars" are visible as they stem from side propulsors. (Such "black bars" are also shown in "Fig. #C10ab" below.)

Fig. #D2c (right): An external (side) view of a spherical flying complex. An example illustrated here is obtained by coupling base to base two Magnocraft type K3. Originally the above drawing is published as Figure F1(b) from volume 3 of monograph [1/4]. (The spherical complex of Magnocrafts and UFOs is obtained when two vehicles of the same type magnetically cling to each other with their floors.) Notice that the coupling of larger vehicles (i.e. types K4 to K10) will produce a more flattened shape of such spherical complexes.

The above photograph is also explained on "Fig. #C2abc" from the web page [ufo_proof.htm - about the formal scientific proof that "UFO vehicles do exist"](#).

#D3. A cigar-shaped flying configuration of UFOs:

The configuration of UFOs (or Magnocrafts) shaped into a cigar is obtained when a number of these vehicles sticks to each other one on the back of the other, similarly as we do it with stacks of saucers in kitchens. Here is a photograph of a cigar of UFOs, and also the repetition of Figure F7(a) from monograph [1/4] which explains how such cigars are formed. Both these illustrations show the external appearance and the way of formation of so-called "stacked cigar shaped UFOs". In case of Magnocrafts the cigar is formed from 7 crew-carrying vehicles type K6, means the same type as UFO vehicles captured on the photograph from "Fig. #D2a" above.

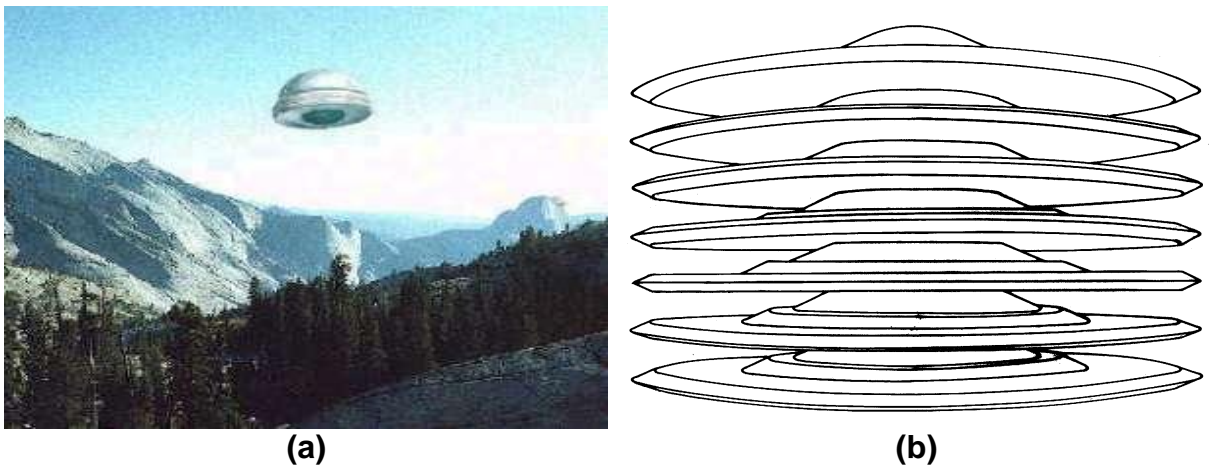

Fig. #D3ab: A cigar formed from UFO vehicles. (Click on the above photograph or drawing to see it enlarged or to shift it to other area on the screen.)

Fig. #D3a (left): A stack of UFO vehicles that forms a "flying cigar". Please notice the action of the "magnetic lens" which significantly deviates the appearance of these vehicles. In cigar-shaped configurations of UFOs such a magnetic lens acts with intensified power.

Fig. #D3b (right): External (side) view of the whole stacked cigar-shaped complex. Such a stacked cigar shaped flying complex represents one of the most efficient configurations obtainable through the magnetic coupling of a number of Magnocrafts or UFOs. This configuration is formed by stacking a number of subsequent Magnocrafts or UFOs of the same type (illustrated is a stack consisting of seven vehicles type K6) one on top of the other, like a pile of saucers stored in a kitchen cupboard. Because on the web page [ufo_proof.htm - about the formal scientific proof that "UFO vehicles do exist"](#) it is

formally proven that "UFOs are already operational Magnocrafts", probably a similar cigar of UFOs exploded near Tapanui in New Zealand in 1178 AD, and also in Tunguska, Central Siberia, in 1908. The outer dimensions of the Magnocrafts and UFOs of the K6 type are: $D=35.11$ meters, $H=5.85$ meters. After landing, $n = 20$ side propulsors present in this type of vehicle scorches a ring on the ground having the nominal diameter $d = D/\sqrt{2} = 24.82$ meters.

It is worth to emphasize here that the filled with magnetic energy propulsors of subsequent UFO vehicles of such a cigar (containing cubical "twin-chamber capsules") are assembled in this cigar in the form which resembles a parabolic mirror in a torch or a "cumulative explosive charge". Thus, the chain explosion of these propulsors is to create a directed shockwave, similar to the one which is formed in present cumulative anti-tank missiles. Because such a starship must always fly oriented with its base perpendicularly to the local course of the Earth magnetic field force lines, its explosion is to form a very characteristic "butterfly" pattern of destruction, which appears in both UFO explosion sites on the surface of the Earth, namely in the [UFO explosion near Tapanui, and also UFO explosion in Tunguska](#). (Originally this is Figure F7 (a) from volume 3 of monograph [1/4].)

It is worth to know, that a similar cigar of Magnocrafts, only that coupled from 6 Magnocrafts type K3, is shown in "Fig. #5a" from the web page [propulsion.htm - about advanced magnetic propulsion systems for flying vehicles](#).

#D4. [A semi-attached configuration UFOs:](#)

A semi-attached configuration is formed when two UFO vehicles, or sometimes even more than two of them, cling to each other magnetically with convex spheres of their upper domes. Here is the appearance and the principle of formation of such a "semi-attached configuration".



(a)

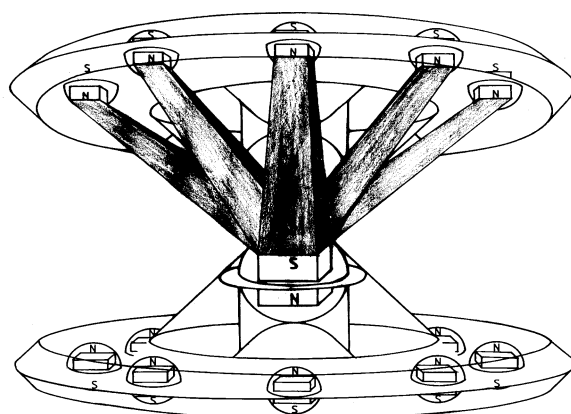

(b)

Fig. #D4ab: A photograph of "semi-attached configuration" (also called a "semi-attached arrangement") photographed in the side view, in daylight, in the "magnetic whirl mode of operation". (Click on the above photograph or

[drawing to see it enlarged or to shift it to other area on the screen.\)](#)

Fig. #D4a (left): A photograph of UFO vehicles magnetically coupled together so that to form a "semi-attached configuration". The propulsion system of this configuration works in the "magnetic whirl mode of operation".

Fig. #D4b (right): An example of the simplest spool-shaped, semi-attached configuration. This spool-shaped arrangement illustrated here is formed by coupling together two Magnocrafts type K3 whose topside domes touch each other. The physical contact between both vehicles is at only one point, thus it is unable to provide a bond sufficient for a safe flight. Therefore the vehicles are bonded with the magnetic forces. The mutual attraction of the main propulsors of both vehicles keeps the configuration joined together, whereas the mutual repulsion of the vehicles' side propulsors maintains the permanency of the reciprocal orientation of both Magnocraft. The propulsors with a high output which lift the entire configuration are: the main one in the lower vehicle and the side ones in the upper vehicle. The main propulsor of the upper Magnocraft and the side propulsors in the lower vehicle produce only a very small output, just enough to maintain the stability of the configuration. Both vehicles have their high output propulsors oriented by unlike magnetic poles towards each other. Therefore the outlets of these propulsors must be joined by the columns of a highly concentrated magnetic field which looks like bars made of a black substance (see also the "black bars" from other Figures). The cross section of these "black bars" reflects the square shape of the Oscillatory Chambers that yield the magnetic field. The above illustration shows the course of several such "black bars". The letters "N" and "S" indicate the polarity of the field yield from particular propulsors. (Originally it is Figure F9 (a) from monograph [1/4].)

* * *

A similar to the above, only that working in the "throbbing mode of operation" (and thus unfocussed because of the action of the "magnetic lens") "semi-attached configuration" of four UFO vehicles type K6, is also shown and explained in "Fig. #5ab" from the web page [memorial.htm - how UFOonauts undermine the evidential value of authentic photographs of UFOs.](#)

#D5. The detached configuration of UFOs:

A "detached configuration" is obtained when two UFOs or Magnocrafts are coupled together in a stable and resilient configuration solely with forces of mutual magnetic attraction and repulsion between their propulsors, while physically these vehicles do NOT touch each other at all.

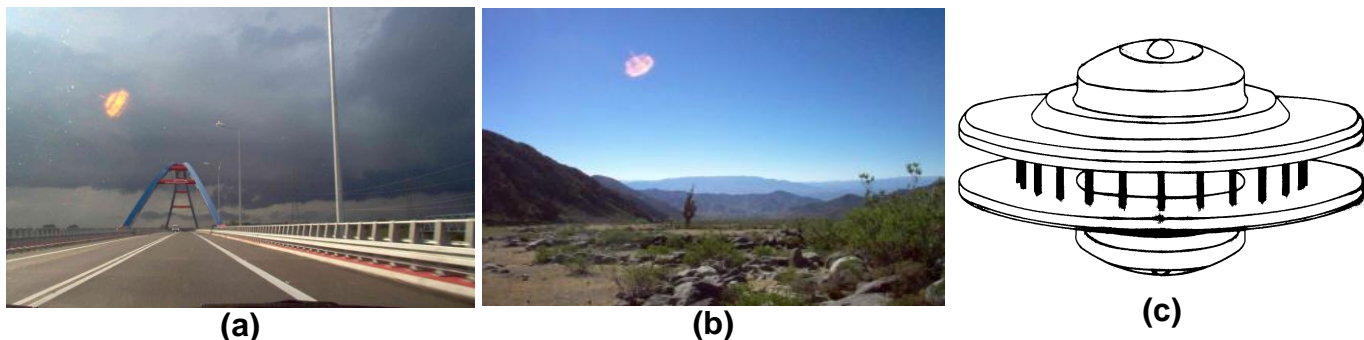

Fig. #D5abc: The daylight appearance of the "detached configuration" (also called the "detached arrangement"), formed from two UFO vehicles and photographed in a side view in the "magnetic whirl mode of operation". The striking in both these photographs is the fact that in spite they were taken by two people who do NOT know each other, and they were photographed in two different parts of the world, still the two "detached configurations" of UFOs that these photographs captured look almost identically. It is worth to add, that also the UFO vehicle captured on the entire series of photographs to which belongs, amongst others, the photo from "Fig. #H3" below, captured a "detached configuration" of UFOs - only that it flies in a different "throbbing mode of operation". (Click on the above photographs or drawing to see them enlarged or to shift them to other area on the screen.)

Fig. #D5a (left): Here is a UFO photograph provided by a reader who identifies himself as "Pawel" (Email: pablano@neostrada.pl). It was taken in August 2004, around 6 pm, on an entrance to the bridge in Wolin, county West-Pomorze, Poland. It supposed to be just a photograph of that bridge and nothing else, as absolutely nothing at that moment of time captured the attention of the photographer. However, accidentally this photograph captured also the invisible to human eyes "detached configuration" of two UFOs type K7 flying in the "magnetic whirl mode of operation".

The curious part of this photograph is that firstly it documents relatively well the principle that the **"UFOs always are flying with their floors positioned perpendicularly to force lines of the Earth's magnetic field"**. This is because just such an orientation of this UFO can be deduced from the direction in which is lined up the shadow from the structure of the bridge (at the time of photographing the Sun was beaming the rays of light from approximately south-west direction). Secondly, through the comparison of the size of that UFO with the height of the truck visible on the bridge, confirmed can be the outcome of theoretical calculation of the dimensions of this UFO type K7 (according to Table F1 from monograph [1/4], the outer dimensions of UFOs type K7 are equal to: outer diameter $D = 70.22$ metres, outer height (base to top) $H = 10.03$ metres).

On the subject what are "detached configurations" of UFOs, how such a UFO type K7 looks like, and what is this "magnetic whirl mode of operation", the reader can find out from subsection F3.1.3 in volume 3 of monograph [1/4], free copies of which everyone can download for himself from a range of totaliztic web sites, e.g. from the page [text_1_4.htm](#).

The photograph from "Fig. #D5a" shown previously is NOT the only photograph of a "detached configuration" formed from UFOs. Other almost

identical photograph showing the same detached configuration looks as follows:

Fig. #D5b (middle): Here is a "detached configuration" of UFOs taken in 2005 in Nevado de Cachi. It captured a configuration almost identical to the configuration of UFOs captured in Poland and shown in left photograph from "Fig. #D5a". This photograph originates from the web page www.rense.com. For scientific interpretation it was posted to me by the reader signed "Melody" (Email: melody@dodo.com.au).

Fig. #D5c (right): An example of the "detached configuration". Illustrated is the coupling of two Magnocraft type K7 mutually oriented base to base. Typically in the full reproduction of this diagram in its lower part a cross section of this configuration is shown that illustrates the polarity of the propulsors in both vehicles (here this lower part is removed - but the reader can see it on Figure F10 in monograph [1/4]). The mutual interaction between propulsors of both vehicles produces two counter balanced sets of forces which keep the vehicles apart, but also simultaneously fasten them together. The first set, formed by the main propulsors, causes the repelling of one Magnocrafts from the other. The second set of forces, formed by the side propulsors of both vehicles, causes an attraction between both Magnocrafts. The columns of the magnetic field joining the outlets of every pair of side propulsors facing each other are shown here in black. As these columns have clearly distinguishable boundaries, they trap the light and therefore they appear as "black bars". The cross section of these "black bars" must be square for the Magnocrafts (and UFOs) of the first generation, as they reflect the shape of the Oscillatory Chambers that yield the magnetic field. (Originally this drawing is shown on Figure F10(top) from monograph [1/4].) It shows an external view of the whole configuration. The shape, location, and the number of visible "black bars" is illustrated. Notice that during an actual appearance of this configuration, the shape of the lower vehicle could become distorted by the action of a magnetic lens. (A best photograph which illustrates this distortion of the lower vehicle is shown in "Fig. #C1c" from the web page [evidence.htm - about material evidence of the secretive activities of UFOnavts on the Earth](#). That "Fig. #C1c" from "evidence.htm" shows the same UFO vehicles that are illustrated here on "Fig. #H3" below.) But the above drawing shows the appearance of this configuration illustrated as it is NOT distorted by the action of any "magnetic lens".

#D6. A carrier platform of UFOs:

A "carrier platform" is formed when under side propulsors of a large "mother-ship" are magnetically attached smaller UFO vehicles, which this large "mother-ship" carries away.



(a)

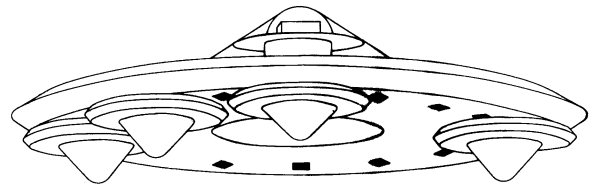

(b)

Fig. #D6ab: A photograph of the "carrier platform" of UFOs. (Click on the above photograph or drawing to see it enlarged or to shift it to another area on the screen.)

Fig. #D6a (left): A photo of a "carrier platform" formed from a large "mother ship" carrying a number of small UFOs. It is originally explained as Figure F14 from monograph [1/4]. This arrangement was photographed over West New York, New Jersey, USA, on July 7, 1967 - see page 111 of the book [6P2] and page 159 of the book [8P2]. A similar carrier platform, but captured at a less spectacular angle, was photographed by W. D. Hall over Australia in 1954 - see [6P2] p. 56, [8P2] p. 66. The above photograph captured the "carrier platform" formed from a large "mother ship" UFO type K5 that carries six small UFOs type K3 suspended under its floor at outlets from side propulsors (see also the explanatory drawing from part "b" to the right). Notice that four out of these UFO type K3 cling to the "mother ship" with their floors, while two next cling with their topside domes.

Fig. #D6b (right): An example of the "carrier platform" of Magnocrafts, i.e. a configuration formed when a number of smaller Magnocrafts are suspended under the base of a bigger mother ship. The distinctive characteristic of this flying arrangement of Magnocrafts is that the main propulsor of each suspended Magnocraft is facing a side propulsor from the "mother ship". The forces that join all the spacecraft together are created as the effect of mutual attraction occurring between one of the side propulsors of the mother ship and the main propulsor of each Magnocraft suspended under it. The illustration shows four Magnocrafts type K3 (out of a total of eight vehicles type K3 possible to be carried by the sixteen side propulsors of a K5 type mother ship) clinging under the base of a K5 type Magnocraft. (Originally this drawing is published as Figure F11 (a) from monograph [1/4].)

#D7. A flying system of UFO vehicles:

A "flying system" of UFOs is formed when several cigar-shaped configurations of UFOs cling to each other by their sides. The outcome resembles a kind of flying platform, or an entire flying city. Photographs of flying

systems of UFOs are very difficult to come by - myself personally I never encountered even one of these. But the appearance of these flying systems if relatively well described by the "Theory of the Magnocraft" - e.g. see Figure F12(a) from monograph [1/4]. Fortunately, the real existence of flying systems of UFOs is documented with their numerous landing sites. Here is an example of one of such UFO landing sites.

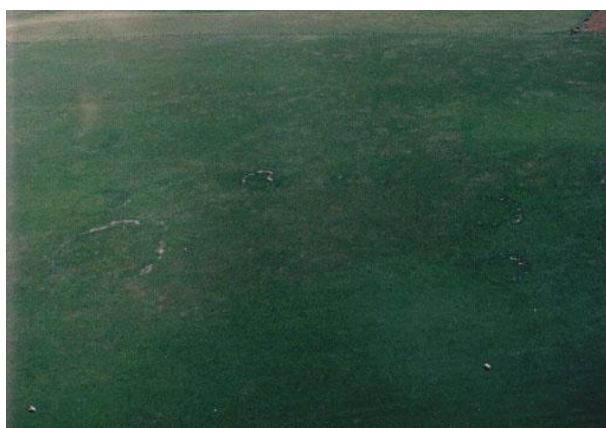

(a)

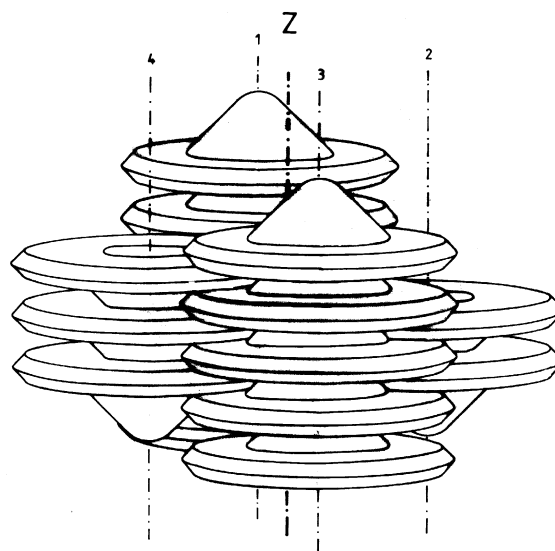

(b)



(c)

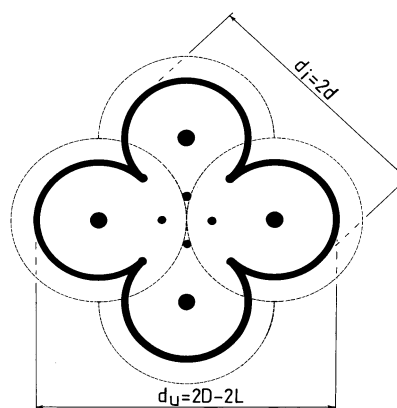

(d)

Fig. #D7abcd: Evidence in support of the thesis that UFO vehicles also form so-called "flying systems". It takes the form of a landing side of a single cell of a flying system of UFOs type K3. It represents one amongst huge number of UFO landing sites that appeared around the site of UFO explosion near Tapanui, New Zealand. The example illustrated above was scorched on the paddock of Mr. Gerrard Eckhoff from Coal Creek near Roxburgh - i.e. on the main line of the fallouts of so-called "china stones" from the Tapanui explosion. The characteristic attribute of a single cell of a "flying system" is that the landing of such a cell scorches in the ground an unique shape of a "four-leaf clover", the origins of which cannot be explained in any other manner - apart from the landing of a single cell of a "flying system" of UFOs. (Click on the above photographs or drawings to

see them enlarged or to shift them to another area on the screen.)

Fig. #D7a (top-left): An aerial photograph of this Roxburgh UFO landing site, taken by Mr Harry Latham of Invercargill on 15 November 1987. In the centre of this photograph visible is the landing site of a flying system of K3 type UFOs, discovered in the paddock of Mr Gerrard Eckhoff of Coal Creek near Roxburgh (on the line of fallouts of so-called "china stones"). The characteristic attribute of such a system is that it scorches on the ground a unique "four-leaf clover" shape which can not be formed in any natural manner. Field examination of the above site confirmed the presence of all the attributes of a UFO landing foreseen by the Theory of the Magnocraft. Notice that apart from the discussed site from the centre of photograph (this shaped like a "four-leaf clover"), the photograph captured also a number of other landing sites of flying systems of UFOs scattered around. These other landings of flying systems were composed of more cigars than just four that typically compose a single cell.

Fig. #D7b (top-right): General appearance of a flying system of Magnocraft. Notice that this configuration of Magnocrafts or UFOs is obtained when four cigar-shaped flying complexes similar to the ones shown in "Fig. #D3b" above, or in "Fig. #5a" from the web page [propulsion.htm - about advanced magnetic propulsion systems for flying vehicles](#), are coupled together with their flanges. This configuration resembles a honeycomb. Only a single cell of such a flying system is illustrated. The example shown here contains four "cigar shaped" flying complexes obtained by stacking together the following number of Magnocrafts type K3: (1) six, (2) two, (3) five, and (4) three. Indexes 1 and 3 are used to mark the magnetic axes of the Magnocrafts oriented in the upright position, indexes 2 and 4 mark the axes of the vehicles oriented in the inverted position. "Z" is the central axis of the cell (the outermost edge of all the Magnocrafts forming this cell must touch "Z" axis). Basic principles involved in the formation of the above cell are explained in Figures F16 and F17 from monograph [1/4]. The single cell from this illustration may be extended by attaching rim to rim an even number of stacked, cigar shaped complexes that would form further similar cell formations. Examples of extended flying systems obtained in this manner are shown in Figures from volume 3 of monograph [1/4]. In turn UFO landing sites formed by such enlarged flying systems are visible in photograph from part (a) above. Originally this drawing is published as Figure F12 (a) from volume 3 of monograph [1/4].

Fig. #D7c (low-left): A ground level photograph of the same landing site from "Fig. #D7a", but this time taken by the author (i.e. by Dr Jan Pajak) in 1988. This photograph illustrates clearly that landings of flying systems of UFOs scorch in the grass shapes that look like a "four-leaf clover". Inside the scorched "four-leaf clover" a white reference disk (1 meter in diameter) was placed, the arrow of which points towards the magnetic north. The measurement of dimensions of this site yielded values: $d_i=6.2$ and $d_u=7.5$ metres, which correspond exactly to those deducted theoretically for UFOs type K3. The photographing of this UFO landing site was more difficult because of the decaying remains of a dead sheep that covered a lower half of the landing. (A part of these sheep remains still is visible.) Similar cases of dying sheep and deer attracted to landing sites of flying cigars and flying systems of UFOs I noted in New Zealand relatively frequent.

Fig. #D7d (low-right): An example of landing pattern scorched on the

ground by Magnocrafts arranged into a single cell of flying systems - similar to the cell shown in "Fig. #D7b". This scorched pattern resembles a "four leaf clover". Notice that the equations deduced for the Magnocrafts allow one to predict exactly the expected dimensions " $d_i=2d$ " and " $d_u=D+d$ " of this pattern for all eight types of crew-carrying UFOs. The drawing illustrates a complicated curve (outline of a "four-leaf clover") of scorched vegetation left by side propulsors around the peripheral of the entire cell of such a flying system (see a thick line composed of small half circles). In order to illustrate main shapes and dimensions of such UFO landing sites left scorched on the ground by flying systems, on the above diagram marked are additional following features, which may NOT be visible on the real landing sites magnetically burned on the ground: (a) outer outlines of four UFO vehicles stacked together into cigar shaped configurations that participated in the cell of a flying system which scorched a given pattern on the ground (i.e. see these four complete circles drawn with thin lines, which represent overhead outlines of four cigar shaped arrangements that are positioned upright); these outlines are shown to realize the number and mutual positioning of the individual vehicles that scorch a given pattern, but - of course - they would not be visible in real landings, (b) a net like pattern of marks (shown with thick dots) scorched on the ground by the main propulsors of each cigar-shaped arrangement, (c) the principles for determining equations that describe two basic dimensions of each flying system (these dimensions are marked with symbols " d_u " and " d_i ", and they should be measured in directions slanted 45 degrees towards each other). (Originally this is Figure F37(a) from volume 3 of monograph [1/4]. A better understanding of terminology used to describe this landing site can be gained by reading the web page [magnocraft.htm - about the "Theory of the Magnocraft".](#))

#D8. Flying clusters of UFOs:

Here is how Figure F13 from volume 3 of monograph [1/4] illustrates the external appearance and the principle of formation of the so-called "flying cluster", which in the case illustrated here is coupled together from two spherical complexes (each such spherical complex is composed of two vehicles type K6).

Similar photographs and drawings that explain the arrangements of UFOs and Magnocrafts into "flying clusters", as well as patterns that these flying clusters leave in crops during their landings, are shown in "Fig. #C6" from the web page [ufo proof.htm - about the formal scientific proof that "UFO vehicles do exist"](#), as well as in "Fig. #5f" from the web page [propulsion.htm - about advanced magnetic propulsion systems for flying vehicles.](#)



(a)

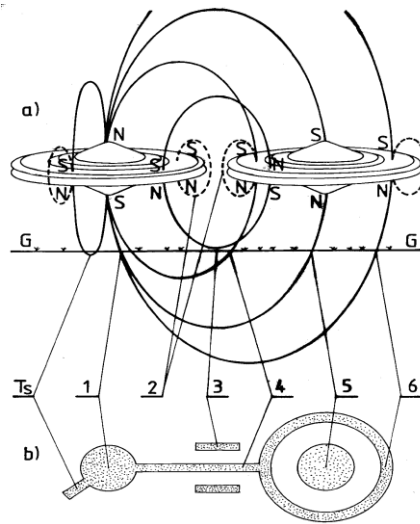

(b)



(c)

Fig. #D8abc: A linear flying cluster of UFO vehicles. (Click on the above photograph or drawing to see it enlarged or to shift it to other area on the screen.)

Fig. #D8a (left): A night time photograph of a "liner flying cluster" composed of two UFOs type K6 coupled together magnetically side-by-side. It was published in the Journal [5P2] "UFO Sightings" (USA), January 1981 edition, page 15. This photo is the best presentation known to the author of the magnetic circuits of a UFO shown from the side view. (A similar magnetic circuits, but this time shown from the overhead view, are captured on the photograph from "Fig. #C4b" from the web page ufo-proof.htm - [about the formal scientific proof that "UFO vehicles do exist"](#).) This photograph definitely confirms that the strands of magnetic field force lines join the outlet from the vehicle's main propulsor with the outlets from side propulsors. The course of these strands of magnetic field force lines is visible because it induces the glow of the air that was ionised by the powerful magnetic field of these UFOs. (The above photograph is published and explained in monograph [1/4], where it appears as Figure P19(c).)

Fig. #D8b (middle): An example of a smallest "flying cluster" of Magnocraft, which simultaneously represents a basic link in every larger flying cluster. Illustrated is one of the simplest cases of the linear clustering together of two spherical complexes type K6. The main advantages of the resultant configuration include: ability to couple together the Magnocrafts of any possible arrangements and types (not only spherical complexes shown here), preserving the original configurations of vehicles that form the cluster, and flying the whole cluster with only one pilot. A flying cluster is obtained through the magnetic bonding of a number of independent vehicles which do not touch one another. Such bonding without physical contact is obtained by the formation of two opposite types of magnetic circuits: i.e. those that repel coupled vehicles (see "separating" magnetic circuits labelled (2) that are shown with a broken line) and those that simultaneously attract the vehicles (i.e. see "tuning" circuits (3) and "coupling circuits" (4), (5) and (6) marked with a thick continuous line). The function of the links for these circuits is performed by "unstable units", i.e. vehicles whose propulsors produce only lifting and attraction forces (i.e. no stabilization forces) -

see the complex on the right. Note that any other vehicles or arrangements can be attached in addition to the above cluster, with the condition that between every two stable units an unstable unit is placed to link them together. The "basic link" of a flying cluster illustrated above can later be extended infinitively by attaching to it magnetically any number of further similar links.

In the upper part (a) of this drawing is shown a side appearance of this linear flying cluster. Illustrated are: the polarization of propulsors (N, S) in the coupled vehicles characteristic for the Northern Hemisphere; examples of magnetic circuits that provide each class of interactions required between both vehicles (i.e. separating (2), holding (4) to (6), tuning (3), and compensating (Ts)); and the penetration of the ground (G-G) by these circuits (this penetration causes the formation of very distinctive "landing marks" in crops, shown in the lower part (b) of this drawing). Note that to keep this illustration simple it has not been shown that every side propulsor of the unstable unit is either linked with the main propulsor of the stable unit by a holding circuit (see (6)) or is involved in a tuning circuit.

In the lower part (b) of this drawing is shown an overhead view of a distinctive landing site which such a linear cluster produces if it hovers at a low height above a crop field with the magnetic whirl mode of operation. The labels link each characteristic element of this site with the appropriate class of magnetic circuits that produces this element. Note that a change in the height of the vehicles must result in a slight alteration of the site's shape and main features. Thus with the change of height also the "depth of the landing" changes, which influences the pattern that is formed by this cluster in a crop field.

Originally this drawing originates from volume 3 of monograph [1/4] where it is shown as "Fig. F13". It is aimed at illustrating a typical appearance of such a liner flying cluster, and also illustrating typical pattern that it forms in crops during a landing or hovering at low heights, when its "magnetic circuits" brush the crops. Notice that a different pattern formed by such clusters is shown in "Fig. #D8de" below.

Fig. #D8c (right): A photograph of "crop circles" formed by a linear flying cluster of UFOs type K6, similar to a cluster shown on the left side "b" of it, as "Fig. #D8b". The above "crop circles", having a total length of almost 50 meters, were photographed in 1990 at Longwood Estate, Southern England. It is worth noticing that the circles shown here include all the elements explained in "Fig. #D8b". The only difference is that this cluster has not touched the ground with its double "tuning" circuits (3 in "Fig. #D8b"), and that it has two "tail" marks formed by the circuits of rotary stabilization (Ts) (these "tails" are attached by both units, located almost perpendicularly to the main axis of this "UFO landing site" in crops).

* * *

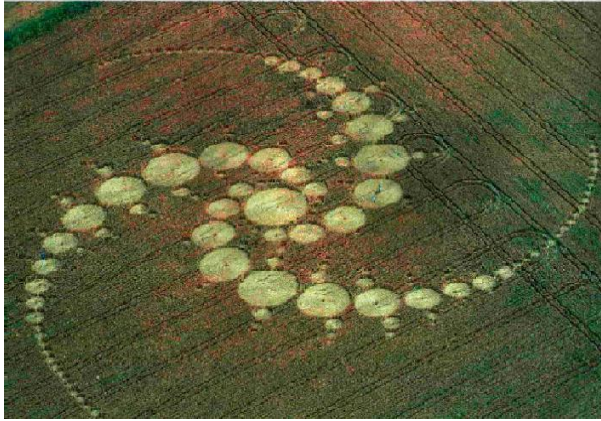

(d)

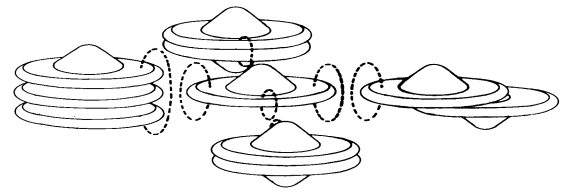

(e)

Fig. #D8de: A two-dimensional "flying cluster". This illustration shows how through appropriate "artistic" coupling together of several UFO vehicles, the intelligent although cunning crews of UFO vehicles can cheat people through the literal "painting" in crops any complicated patterns that they wish. Then agents of UFOnavts mixed with crowds of people declare that these "artistic" UFO landings in crops are "pictograms" which contain messages for humanity from some unknown cosmic intelligences. (In fact these "messages" are from UFOnavts and they read "we cheat you intentionally so that you are unable to work out that we actually do exist, and thus that we can rob and exploit you practically forever". (Click on the above photograph or drawing to see it enlarged or to shift it to other area on the screen.)

Fig. #D8d (left): A photograph of ornamental "crop circle", means a landing in crops of UFOs that are coupled together into a two-dimensional "flying cluster". This type of "ornamental UFO landings" is created by UFOnavts intentionally in order to induce a confusion amongst people, and thus hide better their secretive activities on the Earth. This better hiding of UFO activities on the Earth is accomplished via the purposeful formation of such complicated UFO landings similar to the above. It depends on the practical implementation of the principle which UFOnavts express with the proverb **if you intend to hide a tree, then you need to plant a whole forest around it**. Namely, UFO vehicles sometimes must land in crops and thus they unintentionally create in there "crop circles" - means UFO landing sites in crops. (E.g. this happens when UFOnavts fly underground to park UFO vehicles in underground caves about the existence of which in a given place humans have no idea.) Because such repetitive appearance of UFO landing sites in given places (under which UFOnavts secretly park their UFO vehicles) would induce unnecessary interest of people, UFOnavts intentionally create a large number of similar "picturesque" landing sites in various parts of the world. Thus appearing of these landing sites in given places does NOT induce any more questions of the type "why just here" or "what causes these crop circles to appear just here".

Fig. #D8e (right): A two-dimensional "flying cluster" of Magnocrafts. These are formed through the bonding (without physical contact) of any other arrangements of Magnocrafts listed before. A two-dimensional "flying cross" is illustrated here. Its magnetic circuits that separate subsequent vehicles are

shown with broken lines (these are always accompanied by numerous holding circuits which, for the clarity of illustration, are omitted here but are discussed in subsection F3.1.6 and shown in Figure F13 from monograph [1/4]). (Originally the above drawing of two-dimensional "flying cluster" of Magnocrafts is shown as Figure F6 (6) from volume 3 of monograph [1/4].)

Part #E: Interpretation of photographs of single UFOs flying in the telekinetic convention of operation:

#E1. What is the mode of telekinetic flickering in the propulsion system of UFOs:

After the Magnocrafts and UFOs of the first generation which are described in parts #C and #D of this web page, are build the Magnocrafts and UFOs of the second generation, called here also the "telekinetic vehicles". The UFOs and Magnocrafts of the second generation were not discussed yet in this web page, so for the description of them the entire this part #E of this web page is devoted, while examples of their photographs are shown and discussed in item #E2. Independently from forces of magnetic repulsion and attraction utilised in UFOs during the "magnetic convention of operation", these telekinetic vehicles utilize additionally in flights the magnetic equivalent of inertia, means the phenomenon called telekinesis (which manifests itself in the manner as this would be done by the reversal of friction). Because the "**theory of everything**" called the Concept of Dipolar Gravity states that on just such magnetic inertia is based the so-called "Telekinetic Effect", thus the Magnocrafts and UFOs of the second generation fly utilizing exactly the same principle which causes the telekinetic motion. In this way the operation of these vehicles becomes similar to other known propulsion systems, the principles of which were based on the utilization of inertia, e.g. to hovercraft or to the aircraft propeller.

Describing the Magnocrafts and UFOs of the second generation with the use of technical terminology from subsection #B5 of monograph [1/4], these vehicles can fly in two different conventions, namely in the "magnetic convention" and in the "telekinetic convention". In the magnetic convention their propulsors generate only the phenomena of magnetic attraction and repulsion. Thus in the sense of principles of operation they use for flights, they become almost identical to the Magnocrafts and UFOs of the first generation described in parts #C and #D of

this web page. Also all other phenomena that they then induce will be identical to these induced by Magnocrafts and UFOs of the first generation in their flight with the "magnetic convention". In turn in the "telekinetic convention" their propulsors generate additionally the phenomenon of technical telekinesis. Thus then they fly in the result of the "Telekinetic Effect" action, during which these vehicles generate the characteristic white extraction glow. After this convention of flight is switched on, these vehicles and their crews are getting into the state which is called the state of telekinetic flickering. The material objects subjected to this state switch on (flicker) very fast between two forms of existence, i.e. material form and the form of energy pattern (more comprehensively this is explained in subsection M3 of monograph [1/5]). It is this telekinetic flickering that allows these vehicles to become completely invisible to human sight and cameras, and also allows them to penetrate through solid objects as if these solid objects are made of an easily penetrable liquid instead of a stiff matter.

The state of telekinetic flickering is a name assigned to the principle of operation of propulsion system in UFOs and in Magnocrafts. In this principle the vehicles flicker extremely fast between two states, namely between matter and energy. The more comprehensive description of the "state of telekinetic flickering" is provided on the totaliztic web page [dipolar gravity.htm - about the Concept of Dipolar Gravity](#).

The appearance of the parked UFOs and Magnocrafts of the second generation is almost identical to UFOs and Magnocraft of the first generation described in parts #C, #D, and #G of this web page. Thus to a causal witness who do NOT know anything about the Theory of the Magnocraft, this appearance is almost impossible for distinguishing. But during the flight in their highest convention of operation (i.e. during telekinetic flights), UFOs of the second generation differ drastically from UFOs of the first generation. The reason is that then they emit this white "extraction glow", that UFOs can become completely invisible on the wish of their crews, and also that they can fly through walls and rocks.

#E2. The photograph of an invisible UFO vehicle that hides from people behind the state of telekinetic flickering:

UFO vehicles of the second generation that operate in the telekinetic convention of flight can be recognised easily because they may become totally invisible to human sight and to other human senses. They also can gradually "fade away" from the view on the wish of their crew. When they are invisible, the only thing that sometimes can be registered of them on our photographs, is this subtle, white glow, called the extraction glow. Here is how this "extraction glow" discloses their existence, presence, appearance, and location.



(a)

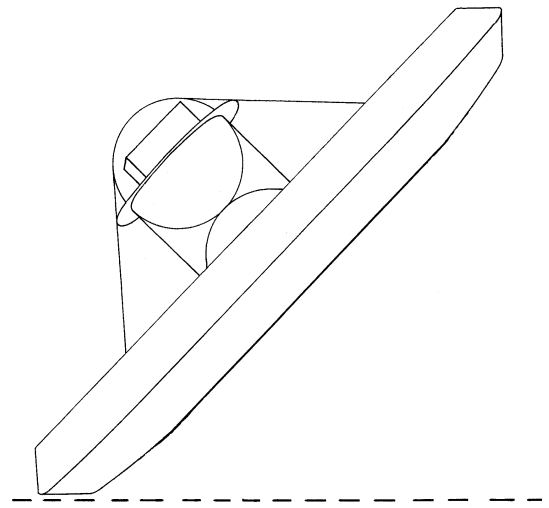

(b)

Fig. #E2ab: An example of UFO type K3 that hovers above the so-called "crop circle" which it formed earlier, in the invisible for human sight "state of telekinetic flickering". Please notice that this photograph does NOT capture the physical surface of the UFO. After all in the "state of telekinetic flickering" UFO vehicles remain invisible to human cameras and eyes. But the camera registered a faint white glow of the air, which is called the extraction glow. It is also worth to notice that this UFO vehicle is hovering under the angle towards the level of the ground. Such angular hovering is typical for UFOs, because their propulsion system requires that their floor is possibly closest to the perpendicular orientation in relation to the local course of force lines of the Earth's magnetic field. Furthermore, it is worth to notice, that UFOonauts clearly created this "crop circle" in order to analyse the reactions and behaviour of people. This is because people examine and photograph this UFO landing site, completely unaware that the invisible for human sight and penetrable by human bodies UFO vehicle still hovers in the centre of it, hidden from their sight due to this "state of telekinetic flickering". (Click on the above photograph or drawing to see it enlarged or to shift it to other area on the screen.)

Fig. #E2a (left): This is very interesting photograph of a UFO vehicle type K3, captured as it hovers just above the surface of a "crop circle" from the village Wylatów in Poland. This UFO is invisible to human sight because it operates in the "state of telekinetic flickering". Also people who just inspect this crop circle walked through this UFO vehicle as it were made of a liquid, and even took photographs by it. However, the physical structure of this UFO cannot be seen with a naked eye, nor captured on photographs. The only thing that a photo-camera can register from it, is this faint white so-called extraction glow which surrounds the outer shell of it, and which is emitted from the surface of all objects that are in the "state of telekinetic flickering" - in this number also emitted from the above UFO vehicle. But if this invisible UFO vehicle captured on the above photograph could be seen, then it would appear approximately as a silver shape shown on the drawing from the right side on "Fig. #E2b".

Because in the "state of telekinetic flickering" a UFO vehicle becomes

completely transparent and invisible to human sight, the above photograph managed to capture also and to show clearly a person which is squatting behind it, and thus which in normal circumstances would be hidden by the shell of this UFO vehicle. Please notice that UFO vehicles operating in this "state of telekinetic flickering" have the consistency of energy, not matter. Thus such UFOs can be penetrated by other objects as if they are NOT present in a given place. People can walk through them remaining completely unaware that they walk through bodies of UFO vehicles and crews of these vehicles. Furthermore, UFO vehicles are also able to fly through solid matter, e.g. getting directly to our homes through walls, or flying through the surface of the Earth to the underground caves in which UFOonauts hide from people their "parked" UFO vehicles. (Similarly UFOonauts that use "personal propulsion" can fly through walls without causing any damage - a photograph of such a UFOonaut that flies through the wall is shown in "Fig. #4ab" from the web page malbork.uk.htm - [about mysteries and curiosities of the Malbork Castle](#).)

Fig. #E2b (right): Here is a drawing of the shape and the position that this UFO from the left side really assumes. The slanting of it towards the Earth results from the requirement that the propulsion of this vehicle works the best when its floor is kept perpendicular to the local course of force lines of the Earth's magnetic field. Both above illustrations originate from the Polish [treatise \[4c\]](#), which provides scientific interpretations for numerous UFO photographs - see Figures Z_2_B2 and R_2_B2 in [treatise \[4c\]](#).

* * *

The above photograph is also shown and discussed in item #20 ("Fig. #4") of the totaliztic web page telekinesis.htm - [about telekinesis for space vehicles and for free energy](#). In turn item #21 of that web page telekinesis.htm (see in there "Fig. #5"), and also item #C3 (see in there "Fig. #1") of a different web page timevehicle.htm - [about time vehicles and time travel](#), illustrates and discusses still another photograph of a telekinetic UFO that flies in the "state of telekinetic flickering".

Part #F: Interpretation of photographs of single UFO starship flying in the convention of time travel:

#F1. The convention of UFO flights that allows to manipulate the elapse of time:

At the very end of the process of development of new starship on the Earth

and on other planets, are constructed the Magnocrafts and the UFOs of the third generation, called also the [time vehicles](#). These Magnocrafts and UFOs also were not discussed yet, thus to the presentation of them devoted is this whole separate part #F of the web page. In turn examples of their photographs are presented in item #F2 below. The Magnocrafts and UFOs of the third generation will utilize three attributes of magnetic fields, namely (1) forces of magnetic interactions, (2) magnetic inertia (i.e. the phenomenon of telekinesis), and (3) internal energy of magnetic fields (i.e. the phenomenon of changes in the elapse of time). Because the mastery of internal energy of magnetic fields allows for the manipulation on time, the Magnocrafts and UFOs of the third generation will have the ability to travel in time. In turn because the change of the internal energy of magnetic fields are going to cause that a kind of a glowing sphere is to be formed in which the space is to emit colourful light, the photographs of time vehicles always show ideally round spheres of the glowing space, in the centres of which sometimes one can see outlines of a UFO vehicle.

Describing the Magnocrafts and UFOs of the third generation with the use of technical terminology from subsection #B5 of monograph [1/4], these vehicles can fly in three different conventions, namely in the (1) "magnetic" convention, the (2) "telekinetic" convention, and additionally also in the (3) "convention of time vehicles". So independently of the ability to fly in the "magnetic" or "telekinetic" conventions, these UFOs are also able to fly in the "convention of time travel". In this convention their propulsors generate changes in the speed of the elapse of time or phenomena of shifting someone to another point in time. For example, these UFOs are able to shift time back, change time to any selected point in past or future, slow time down or accelerate it, etc. Time vehicles generate a whole range of unique phenomena related to time, the most important of which are discussed in subsection N4 of monograph [1/5], and also on the separate web page [timevehicle.htm - about time vehicles and about the idea of technical manipulation on time](#), and [immortality.htm - about immortality accomplished technically through repetitive shifting back in time to years of our youth each time after arriving to an old age](#).

At this point again it should be emphasized, that if someone watches UFO vehicles parked on the ground in which work of their propulsion system is extinguished, then for a person unfamiliar with appropriate theoretical foundations, the appearance of Telekinetic Vehicles and Time Vehicles will be identical to the appearance of ordinary magnetic Magnocrafts and UFOs - means these ones which are illustrated in parts #C, #D, and #G of this web page. Therefore such a person will not be able to distinguish between these vehicles of different generations, and thus also to prepare himself or herself to a type of phenomena that he or she may face in their presence. All three generations of these vehicles will have exactly the same shapes, dimensions, range of types, and will also be constructed from materials displaying the same visual characteristics. For the duration of flights all these vehicles will also couple into the same flying arrangements - as this is shown in part #D of this web page. Furthermore, the mutual similarity of all these vehicles will be reinforced additionally by the fact that the Magnocrafts and UFOs of the second and third generations will be able to switch their operation onto the "magnetic convention" thus displaying the same range of phenomena that an ordinary (magnetic)

Magnocrafts and UFOs do. The differences existing between them become apparent only when they switch on their most advanced convention of flight, inducing in that way the phenomena characteristic for just the second or just the third generation of magnetic propulsion systems. For an expert this difference will become also visible from some technical details (e.g. from the shape of their Oscillatory Chambers). The full understanding of these phenomena requires the familiarity with theories, the description of which is provided in volume 11 of monograph [1/5].

But if someone watches the flying UFOs or Magnocrafts, the propulsion system of which works in their highest convention of flight, then each of these generations induces completely different phenomena. Thus it is easy to be identified. For example, UFOs and Magnocrafts of the described here third generation flying in their highest convention of time vehicles, surround themselves with the ideally round sphere of glowing space - as this is shown below in "Fig. #F2a". Therefore, by this ideally round glowing sphere one can recognise them easily.

On similarly highly advanced magnetic phenomena as this utilised by Magnocrafts and UFOs of the second and third generation, are also based operations of various other technical devices build in times close to the construction of these vehicles, such as "four-propulsor vehicles", "personal propulsion systems", or "tractor beams". These devices will utilise practically such unknown to the present science phenomena as technical telekinesis, telepathic waves, or changes in speed or direction of the elapse of time.

#F2. Photographs of UFOs operating as time vehicles:

It is extremely difficult to meet a UFO photograph that captured a vehicle working in time travel convention. Here is one amongst extremely rare such photographs. About the fact that this is the time vehicle certifies this perfectly round sphere of glowing space that surrounds this vehicle. The time vehicle itself is hidden inside of this glowing sphere - usually occupying less than a half of the diameter of it. The glowing sphere appears only when the propulsion system of such UFOs works in the convention of time travel. In other conventions of operation this ideally round glowing sphere cannot appear.

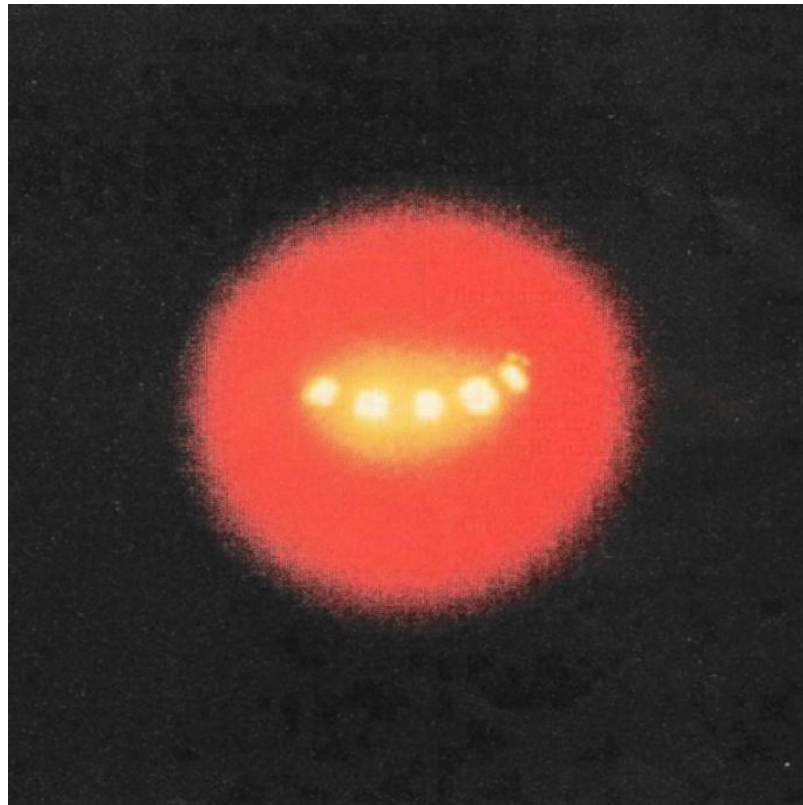

Fig. #F2a: A night photograph of a time vehicle photographed in the "hanging position". Visible is the sphere of glowing air in which the propulsion system of this vehicle carries out the "changes of internal energy of the magnetic field" the outcome of which is this glow of the sphere of the space, as well as the shift of the entire vehicle to another point in time. In the very centre of the sphere glowing white outlines from outlets of propulsors of this UFO are clearly visible. (Click on the above photograph or drawing to see it enlarged or to shift it to other area on the screen.)

Please notice that known is much more authentic photographs of UFOs working as "time vehicles" than just the above photo. Another photograph of such a vehicle is shown as [Fig. #G1b \(right\)](#) from the web page [immortality.htm](#). Further photographs of UFOs operating as "time vehicles" are shown in subsections B3 and C9 from the [Polish treatise \[4c\] - PDF format](#) (see there photographs marked Z_1_B3, Z_1_C9 and Z_2_C9) and in chapter N from volume 11 of [monograph \[1/5\]](#).

Part #G: Interpretation of photographs of four-propulsor UFO vehicles:

#G1. What are these "four-propulsor UFOs":

The basic design of discoidal Magnocrafts or UFOs described above can then be modified to obtain other propelling devices and vehicles. Two most useful out of such modifications are "personal propulsion system" illustrated and described here in part #H, and "four-propulsor Magnocrafts" (or "four-propulsor UFOs") illustrated and described here in part #G. (The detailed description of their designs, principles of operation, and attributes, together with appropriate illustrations, is provided in chapters D and E of monograph [1/4], and in chapters H and I of much older monographs [2e] and [1e].) "Personal propulsion system" is a kind of Magnocraft (or a UFO) that is build into a form of suit that is wear by the user. In this suit two miniaturised main propulsors are assembled into e.g. soles of shoes, while eight miniaturised side propulsors are assembled in a special eight-segment belt. The propelling system received in this manner allows the user to fly in the air, to walk on water or on ceiling, or to jump on huge heights or lengths without the use of any visible vehicle. In turn "four-propulsor Magnocrafts" (or "four-propulsor UFOs") are received through attaching appropriate propulsors to four corners of a portable cabin. The propulsors of this vehicle use "spider configurations" of Oscillatory Chambers. As this was explained before, such "spider configurations" are simple combinations of Oscillatory Chambers that work as alternatives to "twin-chamber capsules". In them, a single central Oscillatory Chamber is surrounded with four side chambers. Thus, the resultant configuration slightly resembles a barrel, while its operation imitates a miniature Magnocraft (or a UFO) that has no crew cabin. When four such "spider configurations" are propelling a portable cabin attached to them, the effect resembles a "log cabin" that is lifted by corners with four miniature Magnocrafts or UFOs. The famous UFO abduction of the late Jan Wolski of Emilcin in Poland, that is described in chapter Q of monograph [1/4], and in chapter O of monograph [1e], was carried out by such four-propulsor UFO.

At this point it should be emphasized, that four-propulsor UFOs can fly in all these modes of operation that are illustrated in part #C of this web page. They also can form almost all these flying configurations that are illustrated in part #D of this web page. Furthermore, they can be constructed in all three generations - the same as the discoidal UFOs. Thus similarly to discoidal UFOs, such four-propulsor UFOs on photographs may form practically unlimited number of various shapes and appearances. However, because of the strictly defined principle of operation and phenomena that they induce, in these huge varieties of their shapes and pictures, always hits our eyes the clear consistency. This consistency in turn allows to clearly distinguish between their authentic photographs from someone's fabrications and fakes.

#G2. An example of photograph of a single

four-propulsor UFO vehicle:

Four-propulsor UFOs arrive to the Earth relatively frequent. Thus frequently they are sighted in various modes of operation of their propulsion systems. Here is an example of one such a photograph of a four-propulsor UFO, on which this UFO was captured in the magnetic whirl mode of operation.

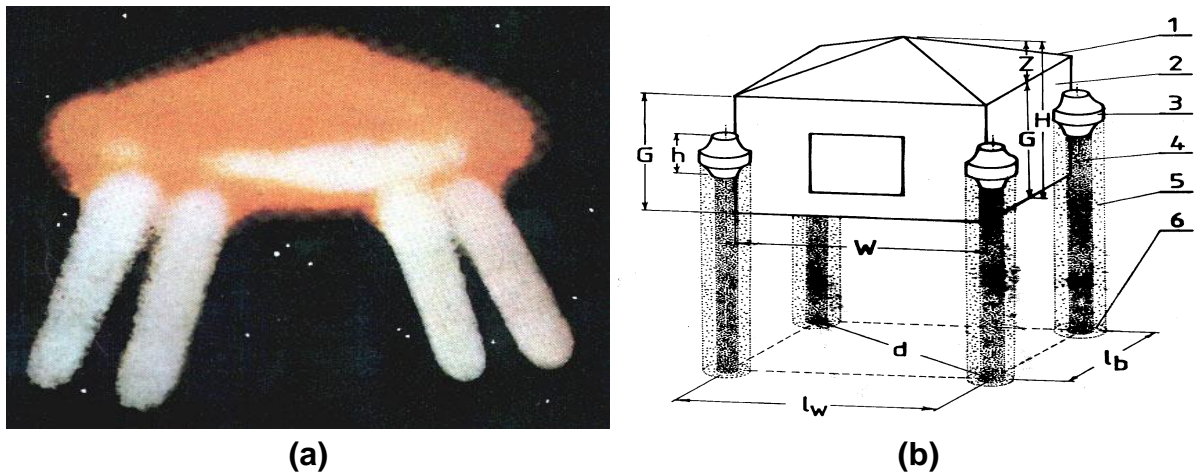

Fig. #G2ab: The appearance of four-propulsor UFO captured in the magnetic whirl mode of operation. (Click on the above photograph or drawing to see it enlarged or to shift it to other area on the screen.)

Fig. #G2a (left): The photograph of a four-propulsor UFO (originally in colour) taken at 11:30 pm on 23 March 1974 near Albiosc in the Vosges mountains in France. It was recorded on film by a local doctor who insisted on remaining anonymous - see page 223 in the book [1P2] by Adolf Schneider, Hubert Malthaner: "Das Geheimnis der unbeakanteern Flugobjekte" (means: "The secret of the unidentified flying objects"). Hermann Bauer Verlag KG - Freiburg im Breisgau, West Germany, 1976, ISBN 3 7626 0197 6. The above photograph presents an ascending UFO vehicle flying in the "magnetic whirl" mode of operation. The crew-cabin of this UFO is surrounded by a spinning cloud of ionised air that emits a red glow. Notice that in New Zealand (southern hemisphere) this red glow would be replaced by a blue one. This in turn corresponds perfectly to the expected colours of the air glow within the range of the propulsors' magnetic poles (i.e. red near N poles and blue near S poles - see also "Fig. #C3ab"). In the four corners of this UFO, white, glowing columns of a spinning magnetic field are clearly distinguishable. Such columns of a whirling magnetic field can be produced only by magnetic propulsors that contain "spider configurations". The mutual orientation of these columns in the above photograph, and the relative proportion of their dimensions, indicate that the pictured vehicle represented a Four-Propulsor Spacecraft, similar to the one shown here in "Fig. #G2b".

Fig. #G2b (right): A general view of the Four-Propulsor Magnocraft. Such a four-propulsor Magnocraft, after two subsequent implementations of a discoidal Magnocraft (see parts #C and #D of this web page), represents the third basic application of magnetic propulsors (the fourth basic application of these propulsors is "Magnetic Personal Propulsion System" presented in part #H).

Illustrated are: the appearance, components, and basic dimensions of this vehicle. Symbols: 1 - a gable roof; 2 - a cubical living compartment containing crew cabin; 3 - one of the four propulsors; 4 - a core of high density spinning magnetic field yield from the "M" oscillatory chamber of the vehicle's propulsors, 5 - a crust of spinning segments of magnetic field yield from the U, V, W and X oscillatory chambers of each vehicle's propulsor; 6 - one of the four scorch marks left on the ground by a low hovering vehicle. Dimensions: H, Z, G, W - describe the size of a cubical like crew cabin (i.e. total height, roof height, wall height, width); d, lw=lb=l - describe the span of the vehicle's magnetic axes; h - describe height of propulsors.

Part #H: Interpretation of photographs of UFOonauts (i.e. crew members in UFOs):

#H1. UFOonauts - means close relatives of humans that secretly raid the planet Earth in their UFO vehicles:

There is an entire range of totaliztic web pages on the subject of UFOonauts, e.g. see [evil.htm - about origins of all evil on the Earth](#), [ufo.htm - about UFOonauts secretly occupying the Earth](#), or [aliens.htm - about the scientific interpretation of authentic photographs of UFOonauts](#). Therefore on this web pages such information is NOT going to be repeated. Instead of this, here shown are examples of photographs that document the cases of actual photographing UFOonauts on our planet. Of course, in order to see a larger number of such photographs of UFOonauts, it is worth to look also at web pages [aliens.htm - about the scientific interpretation of authentic photographs of UFOonauts](#), or [sw andrzej bobola uk.htm - about the church of St. Andrea Bobola in Milicz](#).

#H2. Typical photographs of UFOonauts in the state of telekinetic flickering accidentally captured on our home

photographs:

Because in the so-called "state of telekinetic flickering" UFOonauts that use "personal propulsion system" can without any difficulty enter our homes through walls, sometimes our home photographs accidentally capture also such UFOonauts. Here is an example of one such a photograph.

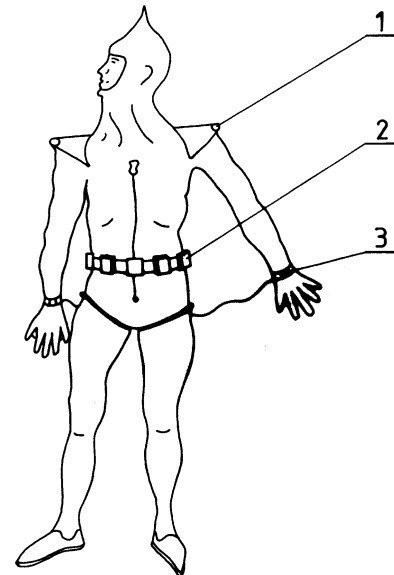

(a)

(b)

Fig. #H2ab: An example of home photograph, which independently of a young person, captured also outlines of a tall UFOonaut of over 2 metres high, disclosed by the so-called "extraction glow" that is yield in the "state of telekinetic flickering". (A similar extraction glow disclosed also outlines of the hidden UFO vehicle shown in "Fig. #E2a" above.) (Click on the above photograph or drawing to see it enlarged or to shift it to other area on the screen.)

Fig. #H2a (left): A photograph which independently from a pretty person photographed in her room, captured also an entire gang of UFOonauts hiding from the human sight behind the "state of telekinetic flickering". Outlines of these UFOonauts discloses a subtle "extraction glow" which is emitted from the surface of objects that carry out the telekinetic motion, and which was captured here by the photo-camera. On the photograph can be clearly distinguished faint outlines of at least 3 UFOonauts that remained invisible for human sight. The person who lived in this room claimed that something "spooky" is in there. Then it turned out that these "ghosts" are simply UFOonauts who for some reasons (easy to deduce) are especially interested in just this young person. Their intensions clearly must be "immoral" since they so carefully hide their presence from people.

Independently from UFOonauts, this photograph managed to capture a miniature, computer-controlled UFO probe, which also moves in the "state of telekinetic flickering", thus leaving on the photograph a kind of three-segment like a "chain" formed from the "extraction glow" that it is emitting (see by the left arm of this young person). Such miniature UFO probes are called "rods" in literature

from the area of UFOlogy. It is almost a rule, that if a given flat is raided by an invisible UFOonaut, then this UFOonaut is always accompanied by several such miniature "rods" or "orbs". Thus if we manage to capture an UFOonaut on a photograph, then on the same photograph it is also worth to seek a "rod" or an "orb" that accompanies this UFOonaut. But the reverse situation is NOT true. This is because such miniature UFO probes can be send in places where UFOonauts do NOT wish or have no time to fly themselves. Therefore if someone photographs such a "rod" or "orb", then it does NOT mean at all that there is an invisible UFOonaut nearby. A comprehensive description of these "rods" and "orbs" is provided in subsection U3.1.2 from volume 15 of monograph [1/4]. In turn their clear photograph with a slightly wider description is shown in item #12 below.

The above photograph, together with an agreement to be published in Internet, was send to me by the reader who named himself "Krzysiek" (e-mail: adunwad@poczta.onet.pl).

More information about the "state of telekinetic flickering" is provided in subsections H6.1 and L2 from volumes (respectively) 4 and 10 of monograph [1/4], the free copies of which are disseminated, amongst others, via this web page.

Fig. #H2b (right): Originally this is Figure E4 (a) from monograph [1/4]. It shows the version of "personal propulsion system" which releases legs of UFOonauts, because it contains main propulsors in the epaulettes. Notice that the hood shown on this photograph that hermetically protects head, can be replaced with e.g. protective helmet of the type shown as (5) on the next "Fig. #H4b". The version of this personal propulsion system with main propulsors in epaulettes is used by UFOonauts relatively frequent. Shown are: (1) one of the two main propulsors; (2) the eight segment belt housing the eight side propulsors; (3) one of the two bracelets placed on the joints of the wrists. These bracelets contain the additional enhancement propulsors (not used for flights) which multiply the user's physical strength when he or she performs heavy work. Note that in order to strengthen the garment, sometimes two crossed braces (suspenders) can additionally join the belt with the epaulettes. The drawing shows also the pelerine attached to the suit along the spine cord and at backs of sleeves. This pelerine increases aerodynamically the fluency of flights (like a present hang glider).

* * *

The appearance of "3+1" finger race of UFOonauts, which in past used to show themselves to people and thus which are well known in legends and in folklore, but whom recently are forbidden to openly show themselves to people, is described and illustrated in "Fig. #7ab" from the web page [memorial.htm - how UFOonauts undermine the documentary value of authentic photographs of UFOs](#), and also on an array of photographs from the web page [sw_andrzej_bobola_uk.htm - about the church of St. Andrea Bobola in Milicz](#). Furthermore, photographs of various UFOonauts are also presented and explained on the web pages [aliens.htm - about the scientific interpretation of authentic photographs of UFOonauts](#), [malbork.htm - about mysteries and curiosities of the Teutonic Knights Castle in Malbork](#), [wszewilki.htm - about mysteries and curiosities of the village Wszewilki](#), or [wroclaw.htm - about mysteries and curiosities of the city of Wrocław](#).

#H3. UFOnavts shockingly frequent break into our homes and our computers:

UFOnavts break to our homes in order to carry out in there various sabotages that serve their evil interests on the Earth.



Fig. #H3: UFOnavts shockingly frequent break into our homes and our computers. The above photograph shows outcomes of sabotaging by UFOnavts quite a significant photograph of UFO which was stored in my computer. This photograph captured the so-called "detached configuration" formed from two UFOs type K7, which fly in the mode of operation called the "throbbing mode". (The "throbbing mode" is described in subsection F10.2 from volume 3 of monograph [1/4].) This photo was taken by Paul Villa of Alberquerque, New Mexico, USA, on 16 June 1963. It is just one frame from the long series of colour photographs of this low-flying configuration of two UFO starship. (The above "detached configuration" is similar to the "detached configuration" of UFOs shown before in "Fig. #D5". A better appearance of the above UFO vehicles can be appreciated in "Fig. #C1c" from the web page [evidence.htm - about material evidence of the secretive activities of UFOnavts on the Earth.](#)) But the most important in the above photograph are effects of the action of the "magnetic lens" (on this web page such "magnetic lens" is described, amongst others, in items #B4, #C9, or #J3). I intended to use this photograph to illustrate the action of such a "magnetic lens". Unfortunately, UFOnavts sabotaged it in such a manner that they destroyed the evidential value of this magnetic lens.

The extraordinary attribute of this photograph is, that already after I scanned it, UFOnavts "broke" into my computer and carried out a very clumsy and clearly visible corrections on it in the vicinity of the UFO vehicle. Because I do NOT have any more the source from which I scanned this photograph, I am unable to scan it

again so that this clumsy corrections are NOT on it (these corrections are absent on the original photograph). The clear goal of UFOonauts for which they carried out this intentionally clumsy "corrections", was to convince the reader that this photograph is a "fabrication" (fake). Such an action that sabotages the evidential value of UFO photographs, is carried out already for a long time by UFOonauts who occupy our planet. Another, extremely cunningly designed example of such sabotage is described on the web page [memorial.htm - how UFOonauts undermine the documentary value of authentic photographs of UFOs](#). It is about time we start to be aware that (1) UFOonauts arrive to the Earth to rob and exploit people, (2) UFOonauts try to stop humanity from realising that people are secretly robbed and occupied by these evil aliens, and (3) in order to hide their existence and activities on the Earth UFOonauts continually keep destroying evidence of their existence (such as e.g. the above clear photograph of a UFO vehicle).

* * *

The above photograph shows a single frame from the entire series of colour photographs of a low flying UFO taken by Paul Villa of Albuquerque, New Mexico, USA, on 16 June 1963. The best reproduction of this series is published in one of the earlier issues of OMNI magazine (probably 1979 issue). Selected photographs are also reproduced on "Fot. #6ab" from the totaliztic web page [memorial.htm - how UFOonauts undermine the documentary value of authentic photographs of UFOs](#), and on "Fig. #C1c" from the web page [evidence.htm - about material evidence of the secretive activities of UFOonauts on the Earth](#). The UFO illustrated above represents a detached configuration formed from two K7 type vehicles, whose manner of coupling is explained in "Fig. #D5c" above. The outlines of a lower vehicle, flying in the inverted position, are warped by the action of a magnetic lens and therefore only partially visible. In high quality copies of these photographs, eleven black bars running between the side propulsors of the lower and upper vehicle are clearly distinguishable. The shape of these black bars is unfortunately impossible to determine here. But in similar cases, eye witnesses have firmly reported them as square in cross section (see subsection S1.1 in monograph [1/4]). The strange history of the series of photographs to which belong the above photo, is discussed and illustrated on na "Fig. #6ab" from the web page [memorial.htm - how UFOonauts undermine the documentary value of authentic photographs of UFOs](#).

#H4. Dwarf-sized UFOonauts:

The Earth is raided by a whole army of various races of UFOonauts. But in order people are NOT aware of their existence, the majority of them constantly hide from our sight. Only UFOonauts who show themselves to us, are these one who look identically as people do, and thus whom we humans take for "ones of us". Photographs of just such human-like UFOonauts are shown in a number of totalizm web pages, e.g. on pages [aliens.htm - about the scientific interpretation of authentic photographs of UFOonauts](#), or

[sw andrzej bobola uk.htm](http://sw.andrzejbobola.uk.htm) - about the church of St. Andrea Bobola in [Milicz](#). Shown below is a photograph of a miniature (dwarf-sized) UFOonaut. This UFOonaut uses "magnetic personal propulsion system" with protective cushions around the waist. Such a propulsion system is frequently used by invisible UFOonauts raiding our homes, especially by the representatives of miniature race of these creatures shown below on a "Fig. #H4a". It is worth to notice that according to so-called "gravity equations" described in subsection JE9.3 from volume 9 of [monograph \[1/4\]](#), such dwarf-sized UFOonauts originate from the planet the gravity of which can be even over 20 times greater from the gravity of the Earth.

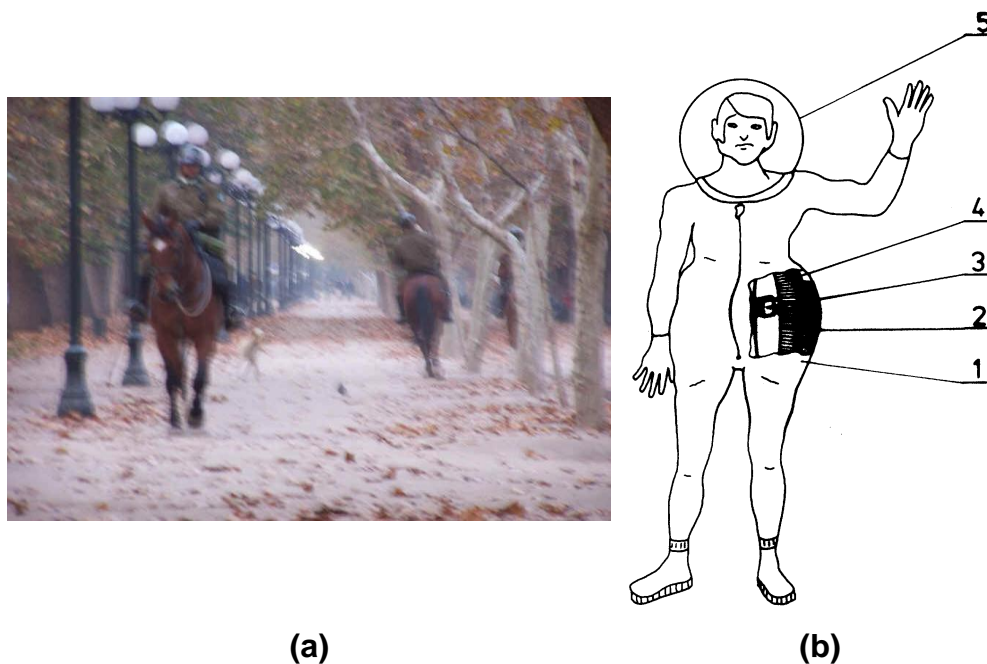

Fig. #H4ab: A photograph of a dwarf-sized UFOonaut that uses a version of the personal propulsion system with protective cushion around waist. (Click on the above photograph or drawing to see it enlarged or to shift it to other area on the screen.)

Fig. #H4a (left): A miniature UFOonaut captured at the moment of time when he runs across a road just behind a horse on the left side of the photograph. These are just such miniature UFOonauts that provide the "grain of truth" to all folklore stories about "leprechauns", "gnomes", "imps", "gremlins", "fairies", and all sorts of other miniature "supernatural" creatures.

According to "gravity equations" explained in subsection JE9.3 from volume 9 of monograph [\[1/4\]](#) - "[Advanced Magnetic Devices](#)", the miniature growth of these UFOonauts results from the fact that they were settled on the planet the gravity of which is tens times higher than the gravity of the Earth. Thus the continuous action of such a powerful gravity force during the newest stage of their evolution causes that their height fell down to only a small fraction of that of humans from the planet Earth. Of course, their small height does NOT change the fact that they are also cosmic relatives of humans, who similarly like the humanity originally come from the planet "Terra" in the constellation Libra. (More about the origins of humanity is explained in subsection V3 from volume 16 of monograph [\[1/4\]](#).)

The above photograph was taken in Chile on 24 May 2004, by someone named Germán Pereira A. The photographer wanted simply take a picture of "Carabineros" (i.e. horse-mounted police) that patrolled the Parque Forestal in Santiago. It was posted to me for preparing an interpretation of it, by a reader that signed the email as "Melody" (Email: melody@dodo.com.au). In December 2004 this photograph was posted on web pages with addresses www.cifae.tk/parquef.htm and rense.com/general53/chile.htm.

An interesting detail of this miniature UFOonaut is that he has a widened waist, and that during the run he moves his legs. This in turn means that he uses a special "magnetic personal propulsion system" with protective cushions around his waist and with main propulsors in epaulettes (instead of soles from shoes). The cushions around the waist in this propulsion system protect hands of the user from being damaged by a powerful magnetic field emitted from the eight-segment belt. In turn the location of main propulsors in epaulettes instead of soles of shoes allows the normal use of legs. Brief description and illustration of this "magnetic personal propulsion system" with protective cushions around the waist, which is used by the miniature race of UFOonauts, is presented in drawing (b) above, and also on the web page [oscillatory chamber.htm](http://oscillatorychamber.htm). In turn the principle of operation of such personal propulsion system with cushions around the waist is explained comprehensively in subsection E4 from volume 2 of monograph [\[1/4\]](#).

* * *

An extremely interesting documentary TV program on "supernatural beings" identical to the UFOonauts captured in the above photograph, I saw in Malaysian TV. It was broadcasted on channel TV3, on Monday, 24 January 2005, at 21:30 to 22:00. It was entitled the "Misteri Nusantara". (As it appeared from the program of this series, it has its own web page with the address misterinusantara.tv3.com.my.) It reported descriptions of numerous eye witnesses who in Malaysia saw small UFOonauts identical to the above creature. In Malaysia these creatures are called "**toyol**". In the TV program all eye witnesses who with their own eyes saw the "toyol", described and drawn them in identical manner, although none of them knew about descriptions and drawings of other ones. And so, the Malaysian "toyol" were drawn and described as very small humanoids, only around 25 cm high, with the figure significantly thickened in the waist. (This thick waist does NOT result from their anatomy - which (the anatomy) is exactly the same like in people from Earth, but from this special personal propulsion system with protective cushions around the waist - see descriptions and drawings of this propulsion system provided in subsection E4 from volume 2 of monograph [\[1/4\]](#).) One boy, whom such a "toyol" troubled quite regularly, compared the size of it to size of a 1-liter empty plastic bottle from "coca-cola". Their head was shown as more prolonged on the top in proportion to human heads, and widened in the forehead part. Their ears were sharply pointed at the upper end, like ears of a dog. The skin of their face was described as dark-green. Their eyes were light-red and quite protruding. In turn teeth grew irregularly with spaces between them and were sharp like teeth of a cat. All observers of these creatures agreed also in describing intentions and abilities of these Malaysian "toyol". For example, all of them stated that these creatures have evil intentions towards people. So someone's noticing that they are

interested in him or her, never means anything good. All eye witnesses also highlighted the habit of these creatures to hide from people, and their ability to disappear from the view. Namely, each person who saw them stated that at the moment when these creatures realized that they are seen by a human, they immediately started to become transparent and quickly fade out from the view completely. In total these Malaysian "toyol" looked exactly as the miniature UFO naut captured on the above photograph. They also looked exactly like these Polish "krasnoludki" which my sceptical brother observed in the garden of my parents - as it is described on a separate web page on the village [Wszewilki](#) listed in "Menu 4" and "Menu 2".

Fig. #H4b (right): It shows the version of personal propulsion with a transparent helmet and protective cushions around the hips. Shown are: (1) the cushions protecting the user's hands from the magnetic field and electrostatic charges; (2) the magnetically impenetrable screen and anti electrostatic insulation around the outer perimeter of the cushions; (3) a single segment of the eight segment belt containing the eight side propulsors; (4) one of the partitions that divide the cushion into eight separate chambers (each of these chambers houses one side propulsor), (5) magnetically impenetrable helmet that protects the head. (Originally it is Figure E4 (b) from monograph [1/4].) Please notice that the protective helmet (5) shown on this drawing, some UFO nauts replace with e.g. a protective hood that hermetically covers the skin of head, or a hood shown previously in "Fig. #H2b".

Part #I: Interpretation of photographs of miniature computer-controlled UFO probes (so-called "rods" and "orbs"):

#I1. What are these UFO probes:

UFO probes are miniature UFO vehicles controlled by small computers. Typically these probes fly on principles of telekinesis. Thus on their photographs usually is captured the so-called extraction glow, not the true surface of these vehicles. UFO probes are used by UFO nauts for carrying out various tasks such as: spying, reconnaissance, filming, hypnotising, tracing, etc., etc.

To confuse people more effectively, UFOlogists use two different names "rods" and "orbs" to exactly the same computer-controlled miniature UFO probes. Because such probes have a very similar shape (of a flat disc) as the crew-carrying UFOs do, on photographs these are captured as two different shapes. Namely, when someone photographs these small disks from a side view, then they look almost like "rods" - thus UFOlogists call them then with the name of

"rods". In turn of they are photographed from the direction of their central axis, then on photos they have round shapes - thus UFOlogists call them then with the name "orbs". **But we must remember, that these "rods" described here in item #12, as well as "orbs" described here in item #13, are actually one and the same kind of miniature UFO probes, only that viewed or photographed from different sides and - or in different conditions of flight.**

#12. Flying UFO probes called "rods":

The name "rods" is assigned in the UFO literature to miniature, computer-controlled UFO vehicles, which typically fly in the "telekinetic flickering" mode of operation, thus remain invisible to human sight. However, sometimes white "extraction glow" that they emit can be accidentally captured on photographs.

Similarly to crew-carrying UFO vehicles, also such computer-controlled UFO probes belong to 8 main types. Dimensions of these 8 types are spanning from several millimetres to around 2 metres. This means the smallest such a computer-controlled UFO probe is as small as a fly. In turn the largest such a probe is as large as an average car.

In the space around the Earth there is a swarm of these invisible to human eyes automatic UFO probes. After all UFOonauts send them to carry out all routine actions, i.e. spying on selected people, checking someone's current position or activities, accumulate data, photograph, take samples, etc. Therefore such UFO probes, or more strictly the "extraction glow" that they emit during the flight, are the most frequently photographed forms of UFOs. (Although for our sight they remain invisible during their flights.) They practically can be found on a huge number of photographs, and also on countless movie films. Only that they are very small, and that they move very fast. Thus people usually do not take notice on their presence on photographs.

UFO probes can fly both, in the invisible for human sight mode of operation called the "telekinetic flickering", as well as in the visible mode. But the visible mode of flight they use very rarely. In fact as a teenager I saw just such a probe that was floating in a stream in a visible mode (because it was shining like gold, I was believing then that I see a "gold nugget"). My sighting of this relatively large UFO probe, because of the size of a "waist watch" (pocket watch), is described in subsection D1 from a Polish treatise [\[4b\]](#) - free copies of which can be downloaded, amongst others, through this web page. On 25 November 2006 I also saw visually one such spherical flying UFO probe in Petone, New Zealand - my sighting is described in item #13 below.

A more comprehensive description of UFO probes called "rods" is provided in subsection U3.1.2 from volume 15 of monograph [1/4].



Fig. #11: A photograph of a miniature UFO probe, which by UFOlogists is popularly known under the name of "rod". This "rod" is that segmented stripe that runs from the top right corner of the photograph and then penetrates through the baby bed by the left hand of a baby. Such automatic UFO probes fly in the "telekinetic flickering mode of operation". The principle of this telekinetic mode depends on a fast disappearing from one place of the space, and then appearing for a fraction of second in another point of space, from where then it disappears again to move to another point in space, etc., etc. Such "flickering" from one place to another place is so fast, that the human eye typically is unable to notice it. Therefore for human sight these UFO probes remain completely invisible, similarly like also remain invisible entire UFOonauts and their vehicles when they remain in the same as such probes "state of telekinetic flickering". But a sensitive photo-camera is able to capture them. Because in the duration of time when the shutter of the photo-camera becomes open, such a UFO probe makes literally hundreds of "flickering", on the photographs thus taken such "rods" usually are captured as stripes composed of a whole number of small segments. Each such a segment represents one "flicker" of this miniature UFO vehicle the flight of which was just captured. Thus in fact such a small UFO vehicle looks just like a single segment from such a segmented stripe. But because in the duration of the time of exposure the probe makes hundreds of such "flickering", on the above photograph this UFO probe is captured as a stripe composed of hundreds of such segments. (Click on the above photograph or drawing to see it enlarged or to shift it to other area on the screen.)

The above photograph should be complemented with the information that the "state of telekinetic flickering" allows this UFO probe to fly through solid matter. This is why this stripe of flashes disappears into the material of the baby bed near the hand of the baby. If the bed was transparent, then we would see this stripe as

it penetrates through the body of the bed and floor below.
Because these UFO probes can penetrate through walls, they are frequently present in our homes - although they remain invisible for us. Only sometimes they are captured accidentally on our photographs - as we see it on the photograph from "Fig. #H2a" above.

#13. Flying UFO probes called "orbs":

An example of photographs of UFO probes called "orbs" is shown in "Fig. #G1" and "Fig. #G2" from the totaliztic web page [landslips.htm - about murderous landslips and mudslides induced technically by UFOs - \(click on this green writing in order to see here a photograph of such an orb\)](#). Thus such photographs are NOT going to be repeated here.

A glowing spherical UFO probes (i.e. these "orbs") are sighted in New Zealand relatively frequent. A comprehensive description of one such a sighting is provided in item #E3 from the web page [newzealand.htm - about mysteries and curiosities of New Zealand](#).

A second time in my life I saw in person such a spherical UFO probe on 25 November 2006. (For the first time I saw such a probe as a teenager - I wrote about it in item #11 above.) Here is how such an "orb" is described by me in the Polish post number #97 entitled "jak zaobserwowałem 'orba' gołymi oczami" (means "how I sighted an 'orb' with naked eyes") to the blog of totalizm the addresses of which are listed below in item #K3 of this web page (I am quoting here the text of my descriptions from that blog of totalizm, after I translated this text into English):

* * *

In UFOlogy the name "orb" is assigned to a miniature computer-controlled UFO vehicle, that has a shape similar to a sphere. The name of it originates from the word "orb" used to describe a kind of [golden sphere that was held in the hand by monarchs of the past](#). (It is interesting that actually a number of past monarchs is portrayed as they hold in their hand just such a gold orb. Is it possible that this orb was just such an "orb" - means a miniature, computer controlled UFO vehicle which [old-time UFOonauts that changed into human monarchs](#) used for implementing personal orders, e.g. for spying or defence?) Most frequently an "orb" is captured on photographs completely by an accident. Examples of just such photographs which show "orbs" are presented on the totaliztic web page [landslips.htm - about murderous landslips and mudslides induced technically by UFOs](#) - see in there "Fig. #G1" and "Fig. #G2". Visual sightings of "orbs" are extremely rare. I personally saw the first one when I was a teenager - the description of it is provided in subsection D1 of the Polish treatise [\[4b\]](#). I saw it then in the top view, when it floated in water of a stream. Because it was probably flattened by optical illusion of the water, it resembled me then not a sphere, but like a kind of gold ellipsoid of a shape and size of a typical (old fashioned) "waist watch" (pocket watch). Sightings of orbs by other people are described in item #E3 of the totaliztic web page [newzealand.htm - about mysteries and curiosities of New Zealand](#) and also in introduction (see item

11 in there), subsection B1 (item 13c), and subsection C8 (item 5) of monograph [5].

My second visual sighting of an "orb", which I intend to describe here, took place on Saturday, 25 November 2006, in the suburb named Petone near Wellington in New Zealand (where I lived then). Around 2:20 pm I went that day for a walk. It was a middle of bright, sunny day, although typically for Petone blow then a rather powerful westerly wind (i.e. a wind blowing from west towards the east of Petone). After around 10 minutes of walk I arrived to a place not far from my flat, in which there was a small UFO landing site scorched on the lawn only several months earlier. This small UFO landing site had a shape of a ring of magnetically scorched grass of the outer diameter "do" equal to "do= 45 cm", while the inner diameter equal to "di= 27 cm". I was systematically watching the evolution of the state of this UFO landing since around a half of year. It always puzzled me how (and of what type) UFO vehicle could scorch in the grass a landing site of such a small diameter. After walking along the same lawn around 20 further meters, I kicked a patch of taller grass that visibly sticking above the rest of the lawn. At that moment of time from the ground ascended fast into the air something of a milky colour. It was a noticeable size, that was comparable to a ping-pong ball. Simultaneously I heard a loud buzzing similar to the noise of electric sparks on a faulty connection of a power-line. The buzzing noise did NOT come from a specific point or from something, but it sounded like all around me. This milky something ascended from my leg directly to my eyes. Firstly it flew towards my right eye to the distance of only around 1 cm from the eye. It flew so fast that the eye had no time to even focus onto a sharp viewing it. So I noticed this something just like a milky, unfocused, flickering patch in front of my eye. Later, after I analysed my feelings, I also realised clearly that this something did NOT form any motion of the air that my skin or my eye would sense. It stopped near my right eye just a fraction of second, then it flew to my left eye, similarly stopping just for a very short moment of time and also making this "flickering". Still it looked like a milky, fast flickering unfocussed patch. After an equally short hovering by my left eye, it again zigzagged to pose itself slightly above the top part of my nose, by the area in which it is commonly believed that we have the so-called "third eye" in there. Through my mind passed then a fast thought, that I scared a large insect of some sort with milky wings and very fast flights. At this point I should mention that this zigzagging of the milky patch in front of my eyes now resembles me typical movements of a white toy with which Maori women from New Zealand play quite frequently. This white zigzagging Maori toy is called [poi](#). I described comprehensively this "poi" toy in subsection C1 from the Polish monograph [5/4]. Perhaps these white toys are kinds of primitive symbols for "orbs" utilised in New Zealand by aliens in past, especially that in 19th century Maori "poi" were shaped differently than at present, and curiously their historic shape excellently reflected the shape of "orbs" and "rods". (In past aliens used to trouble Maoris quite frequently and openly - for details see "Fig. #5" on the web page [sw andrzej bobola uk.htm - about the church of St. Andrea Bobola in Milicz](#).) After an equally short hovering, from the above my nose it shoot under an angle of around 60 degrees upward and in the direction of magnetic south. Quite a powerful westerly wind which blow onto this small thing from the right side, caused no even a slightest deviation of it from the straight southbound

course. It flown all time along a line straight like a bullet. Only at that last stage of the encounter my sight managed to focus on it. So I noticed that the surface of this something was smooth, shining, glossy, clearly distinguishable, with a quite strong blue colour on its highest, top, dome-like part - as if it glow with a blue light. The colour of it was very intense blue - the colour that is closest to it and that I know of, is the one that appears on the surface of water polluted with car oil. Where it was clearly visible, this surface looked almost like a surface of a transparent soap bubble of the diameter of a ping-pong ball, and with a colour of blue, transparent, glowing glass at the uppermost end. Thus in fact the diameter of this spherical something was close to the largest diameter of a gold-coloured ellipsoid (an "orb") that I saw in time of my youth. I clearly saw in this something this spherical dome shape only at the top and bottom ends. (But the bottom-end dome of it was just transparent - means had no any noticeable colour.) In the middle part of it there was a horizontal stripe of the width of around 75% of its diameter, in which nothing was visible at all - as if in that area this something was completely immaterial or invisible. To be honest, these two domes on both ends of this something resembled to me drawings that are prepared by people who sighted two UFO vehicles type K7 coupled together into a spherical flying complex in which (the complex) both side flanges become invisible. Everything that I am describing here happened in a very fast motion, so that the entire this my sighting, starting from the moment of time when this something darted upwards from the ground and begun to induce loud buzzing noise, until the time when it disappeared at a distance, lasted probably even shorter than around 2 seconds. I am perfectly aware of the significance of immediate writing down of our UFO sightings, before details of the sighting loose the focus in our memory. Thus instantly after this sighting of the "orb" finished, I turned back towards the home in order to write down this report. On my way back I analysed all details of my sighting and all my feelings, so that nothing could escape my attention and my memory.

This my sighting of an "orb" provided me with first suggestions as to what from originates this miniature UFO landing site on the lawn - that I described earlier. I begun to believe, that under that particular area there is an underground cave in which UFO-nauts park their UFO vehicles, and these UFO vehicles provide an underground base for just such orbs. The majority of these "orbs" are probably of the size of a ping-pong ball. Thus when they fly up into the air, or when they penetrate under the ground, they do NOT form any visible landings - perhaps apart from causing a telekinetically induced (much faster and taller) growth of the grass in the exact spot which these probes use for entering the ground. (Everything started when I kicked just such a taller patch of grass.) Note that the telekinetic propulsion of UFOs telekinetises the soil, while this telekinetic pollution causes a faster and taller growth of vegetation - as this is explained in item #11 and "Fig. #13" from the web page [newzealand.htm - about mysteries and curiosities of New Zealand](#). Onto one of these "orbs" I probably accidentally stamped when it emerged from the underground in the state of telekinetic flickering. This is probably because it initially flew in the state of telekinetic flickering that in the first stage I saw it as a milky, buzzing patch. Only when this "orb" shot up in order to fly towards the south, it stopped its telekinetic flickering and thus its milky colour disappear so that it become transparent. But

clearly to this underground base of orbs sometimes must fly also slightly larger UFO probes. Probably it was just such a larger "orb" that burned in there this circular UFO landing site which interested me so much. But because this lawn is located almost in the centre of the suburb Petone and from all directions it is surrounded with streets and footpaths, only by an accident this larger "orb" submerged under the ground in the area where grass grew, thus scorching the landing. The remaining submerging took probably place on roads and on footpaths, where these orbs do NOT leave any marks. Thus the undergrounds under this lawn are probably like an equivalent to the Polish "Wylatów", or to crop fields of England, where also underground parkings for UFOs are located. Only that in Wylatów and in England large crew-carrying UFOs are parked, as I explained this more comprehensively on the web page [aliens.htm - about scientific interpretation of photographs of UFOnavts](#).

In the sighting described here my curiosity was erased also by the strange behaviour of this UFO probe. Namely, why instead of flying straight into the air after it emerged from the underground - as it did at the very end, this strange "orb" initially zigzagged for a moment of time in front of my eyes and my nose, similarly like do these "poise" of New Zealand Maoris. Nothing happens without a reason. Thus for such a strange behaviour of the orb also an important reason must exist pre-programmed into its control-computer. I wonder whether this reason is so-called "biometrics", means the identification of people on basis of characteristics of their eyes. Perhaps this "orb", before it flew away, firstly checked whom I am. In order to recognise me, it analysed the "biometric" pattern in my eyes. This in turn would suggest that UFOnavts have records of biometric data in their databanks for every person on the Earth. Such a possible command of identifying who I am would explain why this orb hovered for a short period of time near each one of my eyes. After it identified who I am, clearly its controlling-computer had pre-programmed to quench my curiosity and to reassure me that I do NOT see anything extraordinary. For this reason it then flew over my "third eye" and passed telepathically to my mind this fast thought, that what I see is nothing mysterious, but simply I see a huge insect with milky wings which ascended from the ground.

Another matter by which I am intrigued, is why firstly this orb was white (when it darted upwards from the ground and when it zigzagged), then its white colour disappeared and it become transparent, glossy, and with like a blue glow at the upper dome. I gather that probably in the first phase it flew in the so-called "state of telekinetic flickering" (described more thoroughly on the web page [dipolar gravity.htm - about the Concept of Dipolar Gravity](#)). Only later it changed the state of operation into the flight in the purely magnetic convention. The state of telekinetic flickering is absolutely vital when a UFO vehicle flies through solid matter. This in turn means that the orb almost for sure just emerged from the underground, not from the grass - when I first saw it. At that particular area is probably nothing special under the ground that this orb could investigate. So in connection with this other small scorched ring of a "UFO landing site" distant just around twenty meters on the same lawn, this suggests that in fact there is over there an underground base of "orbs". Thus I have a duty to watch this area closely. (Unfortunately, until June 2008, means until the date of translating this item to English, I have NOT noticed in that area anything else

unusual.)

Finally interesting is also this buzzing noise of the orb like a large insect. I believe that it must be induced by a pulsating magnetic field of this orb. But it was NOT so fast as I would expect from so small UFO vehicle. In fact its frequency was quite close to the frequency of the buzzing of a bumblebee. Now I understand why in one of the books from the cycle "Andreasons Affairs" (most probably it was in the book [2S1.4] by Raymond E. Fowler, "The Andreasson Affair, Phase Two", Prentice Hall, Inc., Englewood Cliffs, New Jersey 07632, USA, 1982, ISBN 0-13-036624-2), the main female hero describes that she was hypnotised by a "bumblebee" which sit on her forehead. So clearly she was hypnotised just by such an orb which I saw.

At the end I would like to direct the attention of the reader that whatever happens to me, for sure also happens to a number of other people, including into this also the reader. So it is interesting how many times the reader also encountered in his or her life such "orb", only that took it for a bumblebee, or for some other large insect. Interesting also whether just such an orb hypnotised the reader in some empty forest or field far from other people?

Part #J: Findings and actions that result from scientific research of UFOs:

#J1. There is an infinitive number of items of consistent and objective material evidence which prove the existence of UFOs and the secretive operation of UFOnavts on the Earth:

UFO photographs interpreted and described on this web page are just a small droplet in the huge ocean of material evidence for the existence of UFOs and for the continuous (although secretive) activities of UFOnavts on the Earth. A whole array of other such objective items of evidence, is presented on the totaliztic web page [evidence.htm - about material evidence of the secretive activities of UFOnavts on the Earth](#). In turn philosophical explanations of reasons why UFOnavts secretly operate on the Earth are presented on the web page [evil.htm - about the origins of all evil on the Earth](#).

#J2. Resolution of the internet discussion list of totalizm:

The exploitation of Earth by UFOnavts: the collective resolution of the internet list totalizm@hydepark.pl regarding official recognition of formal proof on the existence of UFO, recognition of the formal proof on the occupation of Earth by UFOs, and recognition of the Magnocraft as a technical explanation for UFOs

We, 161 participants of the internet list totalizm@hydepark.pl, representing almost every area of life and almost every region of Poland, with a great concern observe the development of present situation regarding parasitic activities of UFOs on Earth. From one side we see the passivity of authorities and adverse of scientists towards increasingly larger problems that are induced by parasitic activities of UFOs on Earth, and we also see the growing tendency to ignore the prevailing collective opinions of majority of people and to base UFO-related decisions on claims just a few non-constructive individuals. On the other hand we notice the overwhelming accumulation of evidence on the continuous presence of UFOs on Earth, evidence of immoral interference of UFOnavts in our public life, and evidence of abductions of people to UFOs combined with biological exploitation of people in UFOs. We are also aware, that in 1981, in the Polish Journal Przegląd Techniczny Innowacje (no 13/1981, pages 21-23) for the first time a formal scientific proof was published, which stated that "UFOs are Magnocraft". Starting from that moment, a growing number of scientific monographs is widely available for all interested, which formally prove the physical nature of UFOs, the parasitic interests of UFOnavts in Earth, the magnetic character of UFO propulsion systems, etc. Until present day these formal proofs transformed the knowledge on UFOs that is available so-far into a single consistent logical structure, proving via this structure that (1) UFOs do exist and they are material space vehicles piloted by morally degenerated relatives of people that originate from space, (2) that morally decadent owners of UFO vehicles occupy and exploit humanity in a hidden manner, and (3) that the design and operation of the space vehicle with magnetic propulsion called the "Magnocraft" provides a complete and correct explanation for all technical aspects of UFOs. We are also aware, that very detailed descriptions of the Magnocraft, as well as all scientific proofs that originate from Magnocraft, are available in a number of scientific publications. Amongst these publications the most up-to-date is the scientific monograph [1/4] by Prof. dr Jan Pajak, entitled "**Advanced magnetic devices**" (4th edition, Wellington, New Zealand, 2003, ISBN 0-9583727-5-6). This monograph is distributed free of charge from numerous totaliztic web sites listed in "Menu 2", for example from sites named [text 1 4.htm](#), or [text 1 5.htm](#), and several others indicated by links from these sites. While being aware of all the above, and simultaneously knowing about responsibility that lies on our shoulders because of our representation of the cross-section of the entire society and all regions of our country, herewith we resolve the following.

#1. We resolve that we officially recognise the formal proof that states that "UFO vehicles do exist". We know that this proof, carried out according to the scientific methodology of "matching attributes", is published and distributed constantly starting since 1981, and that no-one managed to undermine the merit of it. By recognising the significance and validity of this scientific proof, we simultaneously declare and remind, that it has the binding power and that its conclusions, and awareness consequences, should be considered in action of every person on Earth. Especially binding this formal proof is for scientists and for UFO investigators, who on the basis of it have the obligation to undertake the constructive research of goals and manifestations of UFO activities on Earth.

#2. We resolve also, that we officially recognise merit of the formal scientific proof stating that "UFOs are Magnocraft, which are constructed by technically highly advanced, although morally decadent, civilizations of evil parasites from space". We oblige everyone to respect the conclusions and significant consequences of this proof.

#3. Furthermore we resolve, that we officially recognise the formal scientific proof, that "morally decadent owners of UFO vehicles occupy our planet in a hidden manner, and secretly carry out a large scale exploitation of humanity". We oblige every citizen of our planet to encompass the seriousness of consequences of this scientific proof, and to initiate actions that gradually neutralise this occupation and exploitation of people by UFOnavts.

While resolving all the above, we simultaneously strongly encourage all interested, to urgently learn about scientific proofs contained in the monograph [1/4] indicated above, the official and popular recognition of which this resolution declares and also the multitude of consequences of which we are trying to realise with the assistance of this resolution. We also encourage to learn the design, operation, and propulsion system of the Magnocraft, which is the space vehicle that represents an Earth's version of UFOs (means which displays all attributes of UFOs, carries the same operational capabilities as UFOs, and induces the same phenomena which are known from UFO observations).

While issuing this resolution, and granting to it the character of a true representation of our collective views and wishes, we simultaneously hope, that the resolution finally is going to initiate constructive actions and initiatives regarding UFOs, so long-awaited by the society. For example we hope, that it is going to inspire the undertaking of systematic research on UFOs by scientists and by people responsible for our security and our level of informing. We hope, that in all matters regarding UFOs the society starts to draw from collective wisdom and stops following the claims of wrong but noisy individuals, who probably are manipulated by these parasitic UFOs. We hope, that this resolution breaks through the impasse to-date which surrounded the progress of people's rational understanding of the reasons, multitude, and technology of morally degenerated aggressors from UFOs. We hope, that it is to make people sensitive about immoral, parasitic, and hidden character of all activities of UFOs on Earth. We hope that it points the attention of authorities at burning issues of the defence of society from evil exploitation by UFOs. We hope, that it makes everyone interested in the scar from identification implant of UFOs, which (the scar) the majority of us is having on a leg. We hope, that it is going to initiate more intensive observations of UFO activity in our living space, and that it realises that

with appropriate methods and devices which are sensitive at fast telekinetic motion, literally tens of visually invisible, telekinetic UFO vehicles can be registered in our sky in every moment of time (these telekinetic UFO vehicles are usually referred to, as "rods" or "orbs"). We hope also, that this resolution inspires all people to undertake an active self-defence against cosmic aggressors from UFOs.

This resolution was taken on 24 March 2003, in the result of anonymous voting (which was based on pseudo-names) that was open for participants of debates on the internet list totalizm@hydepark.pl. The results of this voting was unanimous - the entire 100% of voting participants gave their votes for accepting this resolution. The participants confirm that the voting had anonymous character, thus the results represent an exact reflection of actual views and wishes of people that voted. In turn because voters represented the cross-section through the entire society and through all regions of Poland, and also because the text of what was resolved represents the collective opinion of voters, this resolution is representative for the stand, wishes, and feelings of significant proportion of citizens of Poland aware of the seriousness of current situation.

#J2.1. My comments on the meaningful circumstances of voting on the above resolution of the discussion list totalizm@hydepark.pl:

The above resolution was taken on 24 March 2003 by participants of the internet discussion list totalizm@hydepark.pl that operated at that time. Namely, all 161 participants of that discussion list unanimously declared that the "Theory of the Magnocraft" provides a complete and correct explanation for all technical aspects of UFOs. And we must remember that in discussion of that list of [totalizm](mailto:totalizm@hydepark.pl) participated also individuals who know very well what are UFOs and Magnocrafts. For example, from the course of discussion of that list and from later fall down of it, stems that a significant proportion of participants of it were just UFOonauts themselves who secretly resided on the Earth and participated in this discussion list in order to "keep eye on what is happening". In turn **since UFOonauts themselves confirmed with own their voting that the Magnocrafts explain all technical aspects of UFOs, we should believe them - after all they know about their own UFO vehicles much more than we do.**

The resolution of the internet list of [totalizm](mailto:totalizm@hydepark.pl) directly concerns this web page. After all, it confirms that we CAN depend on the "Theory of the Magnocraft" as on a perfect tool which allows us to gradually decode all mysteries and secrets of UFOs and UFOonauts. This is why I provided here the full text of the resolution. Please take the notice that the text of this resolution provides also a scientific and a formal justification for the correctness of the interpretation of photographs of UFOs presented on this web page.

The painful and many years long fate of this resolution is described more comprehensively in subsection A4 from volume 1 of monograph [1/4]. The voting on the acceptance of this resolution was carried out in quite dramatic circumstances, under a significant external pressures and with the intense

sabotages of UFOnuts. During this voting UFOnuts demonstrated to participants of the list a power of their occupational forces on the Earth, and their mastery of the situation. After all, soon after the above resolution was voted and accepted, UFOnuts sabotaged until the complete destruction the discussion list of totalizm on which this resolution was developed and accepted. Thus, the list soon needed to be shifted onto another server. Then UFOnuts sabotaged also this next discussion list of totalizm formed on its place on another server. Thus, since the first half of 2005, totalizm was forced to act without a discussion list. So the only communication with practitioners of this philosophy presently are emails and also blogs of totalizm available under addresses listed in item #K3 of this web page. However, even that this resolution turned out to be a painful and costly victory of totalizm, still it is a victory, and this is the most important thing and the thing which really counts.

* * *

Independently from this item and this web page, the resolution discussed here is also published and discussed (but from a different point of view) on several other totaliztic web pages, for example on pages: [ufo_proof.htm](#), [antichrist.htm](#), or [ufo.htm](#).

#J3. Vision distorting factors:

The objective differences between the observed, and real shape of UFOs results from the fact, that in individual cases of observation or photographing of UFOs, a whole array of objective "vision distorting factors" may appear. These factors are outcomes of the unique principles of operation of UFOs, the electromagnetic changes excited in the environment of these vehicles, the materials used for their shells, the capabilities to couple into different flying configurations, etc., etc. Apart from the characteristics of UFOs themselves, these factors stem also from principles of operation of photo-cameras, from human psychology, etc. So there are various classes of these factors. Such "vision distorting factors" may alter completely our perception of shapes of UFO vehicles. In appropriate situations, the distorting factors affect, at random, our observations and photographing, causing the same UFO to be perceived completely differently by various witnesses, or recorded differently on subsequent photographs. The action of these factors reveals itself at random, although frequently. Thus each time there are conditions which trigger them, the perceived shape of a UFO must differ from the real shape of this vehicle. Let us now examine each such factor separately, considering them in the order of their distorting power. (Readers should notice that the identification and evaluation of each factor is only possible because the Theory of the Magnocraft so clearly defines them - for their justification see subsection F9 from volume 3 and P2.1.1 from volume 13 of monograph [1/4].) Here they are:

Class A - factors linked to UFO vehicles:

#1. The ionic picture of a whirl. In the "magnetic whirl" mode of a UFO's operation, propulsors of a given UFO form the spinning cloud of ionized air,

which may completely cover the real surface of a vehicle. This spinning ionised cloud, is called here the "ionic picture of a whirl" - see descriptions of it in subsection F7.3 and in illustration from Figure F27 of monograph [1/4]. Because this cloud is nontransparent, intensive, and displays sharp and clearly defined boundaries, it is taken by numerous witnesses to be the real surface of UFOs.

The classic shape of an ionic picture of a whirl (presented above in "Fig. #C5" and "Fig. #C7") is easily deformed by the vehicle's motion, thus additionally complicating the finding of any repetitiveness in the observed shapes of UFOs. Examples of such deformation of ionic pictures of magnetic whirl, by motion of UFOs, are shown in "Fig. #C6". This deformation is dependent on the orientation of a UFO vehicle, direction of the flight, configuration of the magnetic field that surrounds it, etc. It also depends strongly on the type of UFO vehicle that formed it, and on the intensity of the magnetic field produced by this vehicle, which (intensity) can change smoothly from zero to maximum. Thus, the "ionic picture of a whirl" can provide witnesses with hundreds of various perceptions of the same vehicle - for realising the span of these perceptions see "Fig. #C5" to "Fig. #C7" and "Fig. #D4" to "Fig. #D5".

#2. The ability of UFOs to couple magnetically together several vehicles into various flying configurations. (Similarly like a number of small magnets can couple together forming a bigger magnet.) The shapes of each one out of these countless arrangements drastically differ from each other, and also differ from the shapes of solo flying vehicles. Part #D of this web page reveals, that almost an infinite number of different final forms can actually be obtained through such coupling of individual UFOs. After all a given number of discoidal UFOs of the same type can be coupled into as many as 6 different classes of configurations explained in item #D1. Each one of these classes can further form tens of individual arrangements of flying vehicles that mutually differ in shapes. These in turn may form further arrangements with discoidal UFOs as many as 8 major types, each one of which has different dimensions and external outlines. Furthermore, discoidal UFOs that belong to these 8 types may couple further with four-propulsor UFOs which also belong to 8 major types. All these may in turn couple with various vehicles of a generation that differs from their own (after all UFOs can belong to one out of 3 existing generations). In the result, practically any possible number of varying shapes and configurations of flying UFOs can be accomplished. Figures from part #D of this web page confirm, that UFOs in fact do produce each one of these multitude of different coupled forms. For example, the vehicle (a) from "Fig. #D6" is not a UFO of an entirely new shape, but a flying platform formed from a number of discoidal UFOs. This ability of UFOs, that a number of such vehicles can be coupled magnetically into various flying arrangements, causes that observers of these vehicles empirically never are able to agree about the real shape of UFOs. This is especially obvious when shapes of illusive telekinetic UFO probes called "rods" or "orbs" are being discussed (these "rods" or "orbs" are described in part #1).

#3. The action of a "magnetic lens". This action is especially confusing, as it may significantly alter the apparent shape of a UFO. It manifests itself through several different effects.

The most frequently appearing one out of these different effects, depends on the complete disappearance from the view of the entire hulk of a UFO, and

remaining visible only the outlet from the twin-chamber capsule from the main propulsor. The explanation of this phenomenon is described in item #C9, while it is illustrated in "Fig. #C9ac". This result of the magnetic lens action is frequently revealed and reported when a witness observes an ascending UFO vehicle from underneath. Because of this effect, the discoidal UFOs are perceived by eye witnesses as diamond shaped or square objects. This phenomenon is responsible for many square shapes of UFOs. At this point it must also be noted, that just because of this effect, at the beginning of observation UFO observers frequently notice a UFO in the discoidal shape. But then, in the result of action of the magnetic lens discussed here, this discoidal shape gradually changes into a rhomboid (diamond) or a square shape. In this way **wild opinions are born, about apparent capabilities of UFOs to change their shape**. This in turn builds up a myth about a "non-material" character of UFOs. Such opinions disseminated by sensation thirsty pseudo-researchers, who simultaneously are not familiar with principles of functioning of UFOs, introduce even more confusion into already misinformed society.

A next manifestation of the action of UFO magnetic lens, is making totally invisible, or visible only partially, these parts of UFO vehicles, which are located close to propulsors. In such way side flanges of UFOs, and parts of their topside domes, may either become deformed (e.g. enlarged) or sometimes disappear completely - as illustrated in "Fig. #C2" and "Fig. #D3".

One more manifestation of the action of magnetic lenses of UFOs, is the dynamic distortion of the apparent shape of visible parts of UFO vehicles, in a similar way as objects partially submerged in a transparent liquid can be distorted. This effect causes the hemispheres from UFO shapes to be seen as ovals, cones to be seen as egg shaped, convex shapes may appear as flat forms or even as concaves, parts of side flanges normally hidden behind UFOs may appear on the side of these UFOs or on top of them - giving an impression of wings or tails that protrude from the roof or from the side of UFOs, etc. An excellent example of this type of distortion is an apparent deformation of a lower UFO in "detached configurations" shown in "Fig. #H3" (this deformation is visible the best on other photographs of the same UFO, e.g. see "Fig. #C1c" from the web page [evidence.htm - about material evidence of the secretive activities of UFOnavts on the Earth](#)) - which shows exactly the same configuration of K7 type of UFO vehicles).

#4. The emission of various signals of lights. During darkness or poor daily visibility, eye witnesses' reports and photographs reveal only shapes made of lights emitted by UFOs. Thus the real form of UFOs remains hidden behind these lights. Because UFO vehicles have a huge diversity of sources of lights (e.g. propulsors, ionising capability of magnetic circuits, plasma whirl, SUB lamps, lightning of crew cabin), each one of these sources of lights is capable of sending a whole game of various signals. The confusion about real shape of UFOs caused by such lights is huge. "Fig. #c3" and "Fig. #C9" illustrate how much distortion and concealing of the real shape of UFOs such lights may induce - see also descriptions from subsection P2.13.2 of monograph [1/4].

#5. "Black bars" of a magnetic field. Columns of a powerful, fast-pulsating magnetic field with clearly marked boundaries, yielded by propulsors of UFOs, may trap light and look as though they were made of a black material. This

phenomenon is explained in subsection F10.4 of monograph [1/4]. Thus, for some witnesses, and also on some photographs, these columns of magnetic field may appear as solid components protruding from UFO vehicles. They are called "black bars". When combined with the action of a magnetic lens, these black bars may significantly alter the perceived shape and appearance of UFOs - see "Fig. #D2b".

#6. The transparency of the UFOs' shell. The shells of UFOs is made of transparent mirror like material, very similar to our present mirrors. The degree of transparency and light reflection of this material is smoothly controlled by the crew. Therefore, if the crew so wishes, the shell one time can be completely transparent like a window well washed. On the other occasion, the same shell may completely reflect light like a mirror. In this way for an outside observer it looks as made of a polished tin. Also all the stages of the continuum between these two extremes can be obtained. This ability of shells of UFOs to become transparent, causes that in some circumstances various details of internal design and furnishing of these vehicles can be observed by outside witnesses - especially when the shell of a UFO is looked through at an angle close to 90 degrees. Simultaneously the outlines of the external shell remain unnoticeable. For example in Figure P6 from monograph [1/4] the spherical casing of main propulsor, and the crew's cabin ceiling are clearly visible. In turn completely disappeared from the view the transparent topside dome. Thus, while analysing the photograph from Figure P6 of monograph [1/4], one could obtain a completely false impression about the shape, size and location of topside domes in UFOs type K10.

In order to make the confusion even stronger, hulks of some UFO vehicles which carried out a long horizontal flight just above the surface of Earth, are getting covered with a layer of black "onion charcoal". This "onion charcoal" is described in subsection O5.4 of monograph [1/4], and illustrated on the web page [evidence.htm - about material evidence of the secretive activities of UFOonauts on the Earth](#). In such cases UFOs do not look metallic - like made of a new tin, or transparent, but completely black. This black surface introduces further distortion and disagreement regarding the shape and appearance of UFOs. To be more funny, when the layer of this "onion charcoal" reaches too large thickness, it cracks like a dried mud. Through these cracks the fire of glowing and slowly pulsating propulsors of a given UFO starts to be visible. Everything together resembles a skin of snake, which covers some sort of a fiery, rhythmically breathing body. In this way UFO vehicles start to be described not as machines, but as living fiery creatures, or so-called "dragons".

#7. Various elements protruding from UFOs (e.g. legs, ski undercarriages, periscopes). These may also significantly change the appearance of the observed vehicles. Especially if they are accompanied by a plasma whirl, which is deflected by these elements, thus forming various additional shapes and features.

#8. Ability of UFOs to fly with huge velocities. UFOs can fly in the Earthly atmosphere much faster than rifle bullets. Thus photographs of UFOs can capture them in places where human eyes do NOT see them. Furthermore, in such huge velocities UFOs pile up waves of the air which are also registered on photographs.

#9. A high frequency of electromagnetic phenomena that are formed by propulsion systems of UFOs. Thus whatever human eyes can see in UFOs as smooth surfaces or solid forms, in reality can be just a fast flickering of various electromagnetic phenomena caused by the UFO propulsion system.

Class B - factors linked to photo-cameras:

Photo-cameras are actually kinds of "technological eyes" which see things much more different than human eyes do. Therefore, cameras are also sources and reasons of the distortion of apparent shapes of UFOs captured on authentic photographs of these extraterrestrial vehicles. Here are the most frequent sources of the distortion of UFOs caused by cameras:

#10. Sensitivity of photo cameras and their ability to record faint lights that are invisible to human eyes. This sensitivity causes that authentic photographs of UFOs usually capture more lights and more shadows than the human eyes do.

#11. The ability of photo cameras to "freeze" and capture components of a fast motion. In this manner phenomena which human eyes see as strands or solid surfaces, on UFO photographs can come out as e.g. chains of flashes or as frozen in the motion segments of the magnetic circuits of UFOs which ionise the air and cause it to glow.

#12. The ability of photo cameras to capture pictures of very fast objects. In this way photographs capture and record pictures of UFOs which fly fast like bullets and thus human eyes are unable to see them.

#13. The ability of photo-cameras to work with very long times of exposure. This in turn spreads shapes of UFOs and e.g. actual shapes of these vehicles are turned into long strands.

Class C - factors linked to people:

The above objective factors cause the distortion of real shapes and pictures of UFOs, which can be captured even on photographs and films. Of course, independently from these, at work are also numerous subjective factors, which cannot be recorded on photographs, because they originate from minds of observers. These subjective factors hold us back equally effectively from learning the real shape of UFOs. The most frequently acting out of such subjective factors are:

#14. Purposeful change of the shape and appearance of UFO vehicles carried out by their crews through the use of devices in subsection N3.2 of monograph [1/4] called "modifiers of appearance". In the effect of this change, UFO vehicles start to look like helicopters, aeroplanes, kites, automobiles, motorcycles, various animals, etc. - for examples see descriptions from subsection T4 and VB4.1.2 of monograph [1/4].

#15. Telepathic manipulation of views of witnesses that see given UFOs. This manipulation forces such witnesses to take UFOs for something well known to them, and orders them to not take any notice of these vehicles. More details on this subject is provided in subsection VB4.1.1 of monograph [1/4].

#16. Inability of individual people to exactly remember, and later recall, of all details of the shape of observed UFOs. This causes that in drawings of eye witnesses many vital details of UFOs are missing, or that these details are

located in wrong places, under wrong angles, etc. The most frequent distortions of the UFO shapes caused by such subjective inability to remember of all details include: (1) overlooking of the side flange that surrounds the main body of a UFO, (2) drawing the floor of a UFO without base concave - i.e. as a flat panel that contains only a square porthole which represents the outline of the Oscillatory Chamber from the main propulsor, (3) drawing of a solo vehicle with a lower convexity as if it is a spherical flying complex of two vehicles, and (4) functional interpreting of "black bars", their slanting, or starting them in a wrong point of UFO vehicle (e.g. through their positioning as in "Fig. #D4b", while in reality they run as shown in "Fig. #D5c").

#17. The concealing propaganda of UFOnavts. This propaganda spreads amongst people only misleading photographs and misleading drawings of UFOs. Simultaneously it destroys and removes from circulation these photographs and illustrations of UFOs which show their real shapes. Even my internet web sites, in which I try to illustrate real shapes of UFOs, are continually sabotaged by UFOnavts. In this way illustrations that show true shapes of UFOs constantly need to be repaired, and a large proportion of time cannot be retrieved by interested viewers.

If during an actual UFO observation or photographing, more than one of the above factors acts simultaneously, the resultant perception of the UFO's shape is able to confuse even the most careful observer, or the most experienced investigator. For this reason the factors listed here have contributed to over fifty years of difficulty in piecing together the enigma of real UFO shapes. Only a theoretical approach to the problem, achieved through the formulation of the "Theory of the Magnocraft" described in chapters C to F of monograph [1/4], allowed a breakthrough in this ocean of misinformation. In this way, a single source from which the shapes of all UFOs originate, could be discovered. Also, various reasons for the distortions of this real shape of UFOs can now be disclosed. Thus, thanks to the "Theory of the Magnocraft", all UFO shapes can now be explained.

Part #K: Summary, and the final information of this web page:

#K1. Summary of this web page:

If, on the basis of my already over 30 years long research of UFOs, I would like to define what exactly these UFOs are, then my definition would be as follows: **"UFOs are 'temporary simulations' which imitate the shape and behaviours of starship of the design and principles of operation of**

the **Magnocrafts** (i.e. the spaceships propelled by a pulsating magnetic field) and confront people from the Earth in a manner which is to inspire the research and truth-seeking through making an impression that UFOs are piloted by morally decadent relatives of humanity that live on distant planets to secretly raid the Earth in order to rob the humanity from its biological resources (mainly from ovule and from sperm which supposedly are used on planets of UFO-nauts for the production of so-called 'biorobots'). The expression "temporary simulations" from this definition requires a wider explanation. But because this expression is already elaborated comprehensively on many my other internet web pages, e.g. on web pages [day26.htm](#), [god.htm](#), [ufo.htm](#), I am NOT going to repeat these elaborations here.

The definition of UFOs provided above highlights several attributes of UFOs, each one of which is worth of a careful explanation. Here these are:

1. UFOs are spaceship. Means these vehicles are NOT reflections of lights, balloons, human imagination, etc., as this continually are trying to convey to people **UFO-nauts that impersonate important figures on the Earth.** UFO-nauts that raid the Earth in these UFO vehicles are actually cosmic robbers and exploiters in whose vital interest is to disallow people to realise that UFO vehicles do exist at all. Therefore UFO-nauts continually hide from people, while if someone still manages to see or to photograph their UFO vehicle, than via their "agents" on the Earth, and also via the hypnotic and telepathic commands programmed in minds of intellectually weak people, UFO-nauts try to convey to the rest of humanity, that these were NOT UFOs at all, but reflections of lights, balloons, illusions, imagination, etc., etc.

2. UFOs use magnetic propulsion systems. The propulsion system is already well known to us under the name **Magnocraft**, while for the detailed description of it the reader can reach to chapter F from volume 3 of monograph [1/4] available free of charge, amongst others, via this web page. Briefly this propulsion system was discussed on web pages devoted to the Magnocrafts, which are listed in menus from the left margin, e.g. on the web page **magnocraft.htm - about the "Theory of the Magnocraft"**.

3. All users of UFO vehicles are cosmic relatives of the humanity. This in turn means, that no matter what size they would be, nor from what planet they would raid the Earth, all UFO-nauts originally come from the planet called "Terra" (from the Libra constellation), from which the entire cosmic family of humans originally come. Only that already around 500 millions of years ago people spread from the planet Terra and settled on many other planets of the cosmic space, not long ago arriving also to the Earth. In the mean time these descendants from Terraneans went through further stages of evolution on their present planets, so that in present times all of them slightly differ between themselves.

4. All UFO-nauts are robbers. The Earth is at present under the complete control of the morally most decadent descendants of former inhabitants of the Terra planet. In fact UFO-nauts are cosmic bandits and robbers, with which none self-respectful civilisation wishes to have anything to do. These robbers cut off the Earth from the rest of the universe with their military spaceships, so that no-one can help the humanity (in the universe all civilisations are afraid of these

morally degenerated bandits and robbers). UFOonauts also secretly rob and exploit the humanity since the beginning of times. For example, we are already warned of their existence and activities by the [Bible](#) which calls them "devils", "dragons", "serpents", etc. When the knowledge and technology raises too much on the Earth, so that our cosmic robbers from UFOs are endangered that people may discover their secretive robbery, then these UFOonauts cause some kind of technological [cataclysm on the Earth](#) (i.e. a technically induced cataclysm similar to these described on the totaliztic web pages [landslips.htm - about murderous landslips and mudslides induced technically by UFOs](#), [katrina.htm - about hurricanes formed technically by UFOonauts](#), [day26.htm - about murderous tsunami formed technologically by UFOs](#), or [plague.htm - about medieval plague prepared for humanity by UFOonauts](#)), which sends people again to caves and on trees, so that the building up of the human civilisation must begin from the very beginning. (Our planet and humanity went already by at least three such cataclysms during just last 40 000 years.) The most vital resource robbed by UFOonauts from the Earth is the human ovule and sperm, from which they raise "biorobots" means descendants of people whom on planets of UFOonauts serve as slaves doing all dirty works, e.g. working as servants of UFOonauts, as prostitutes, miners, builders, etc.

UFOonauts that rob the Earth practice an immoral philosophy which on totaliztic web pages is described under the name [parasitism](#). This philosophy causes, that UFOonauts do NOT have neither conscience nor any moral breaks in their robbery raids on the Earth. Therefore in old days humans used to call them "devils", "bad witches", "imps", "mares", "fairies", etc. In fact subsection V9.1 from volume 16 of monograph [1/4] proves formally that "former devils are actually present UFOonauts". In turn from reports of people that were abducted to planets of UFOonauts it transpires that in spite of everything that UFOonauts accomplished, or stole from other civilisations, and in spite of their advancement in science and technology, in fact on their own planet they still practice the slavery system very similar to the one that existed in ancient Roman Empire. Their slavery system is so similar to the slavery of ancient Rome, because most probably Rome was modelled on their own planet by the first rulers of Rome who were [UFOonauts that only impersonated people](#). Independently from practicing slavery, the society of these "free" UFOonauts is still subdivided into casts and classes which mutually persecute and exploit each other. Their women are the subclass that is treated only slightly better than slaves. In turn almost a half of their "free" citizens from the UFOonauts' planet is locked in special "correction camps" which resemble the concentration camps created by Hitler. Thus it should NOT surprise anyone, that planets of UFOonauts used to be called "hell". This is the kind of creatures which enslave the Earth for last tens of thousands of years, deciding about the future of humanity and defining the social system on the Earth which because of them must be similar to their own system. It is horrifying just to think where they direct the fate of our civilisation. More about these evil UFOonauts and their deeds is explained on numerous web pages of totalizm, e.g. on pages [evil.htm - about the origins of all evil on the Earth](#), [ufo.htm - about UFOonauts that secretly occupy the Earth](#), or [aliens.htm - about scientific interpretation of photographs of UFOs](#).

This web page finally dispersed parts of the secrecy which these robbers and

oppressors of the humanity are surrounding their UFO starship in which they secretly arrive to the Earth from distant planets of their parasitic civilisations.

#K2. If someone has doubts - let discuss them constructively:

It somehow happens so, that publications and web pages of [totalizm](#) present material evidence and logical deductions which in many people induce shocks. The reason is that all people are continually exposed to the loud propaganda of UFOnuts bombarding everyone with messages of the type that UFOs do NOT exist, that respectable person should NOT discuss matters related to UFOs, that only drunks and drug users see UFOs, etc., etc. Therefore, if someone is unable to get over these deductions or evidence, then I suggest to discuss honestly his or her doubts. After all, various theses of totalizm are discussed on a number of internet groups and forums. For example, in the Polish language these are discussed on the forum addressed www.totalizm.eu. In turn in English these theses are discussed on Google discussion groups at the address groups.google.com (most frequently theses of totalizm are discussed in there on threads from groups "sci.physics", "alt.philosophy", "alt.religion", "alt.ufo", or "alt.alien.research").

#K3. Blogs of totalizm:

It is also worth to check periodically the blog of totalizm available under address totalizm.wordpress.com and totalizm.blox.pl/html. (Notice that all these addresses hold the same blog with the same content of messages.) On this blog many matters discussed here are also explained with additional details written as new events unveil before our eyes.

#K4. In the future this web page is going to be improved and extended:

Namely, it is going to be updated and extended as soon as I manage to find new interesting UFO photographs that are worth of scientific interpretations. I invite to visit this web page again after some time.

#K5. How with the web page named

"skorowidz links.htm" one can find totaliztic descriptions of topics in which he is interested:

A whole array of topics equally interesting as these from the above web page, is also discussed from the angle that is unique to the philosophy of totalizm. All these related topics can be found and identified with the use of **content index** prepared especially to make easier finding these web pages and topics. The name "index" means a list of "key words" usually provided at the end of textbooks, which allows to find fast the description or the topic in which we are interested. My web pages also has such a content "index" - only that it is additionally supplied in green **links** which after "clicking" at them with a mouse immediately open the web page with the topic that interest the reader. This content "index" is provided on the web page named **skorowidz links.htm**. It can be called from the "organising" part of "Menu 1" of every totaliztic web page. I would recommend to look at it and to begin using it systematically - after all it brings closer hundreds of totaliztic topics which can be of interest to everyone.

#K6. Emails to the author of this web page:

Current email addresses to the author of this web page, i.e. officially to **Dr Eng. Jan Pajak** while courteously to **Prof. Dr Eng. Jan Pajak**, at which readers can post possible comments, opinions, descriptions, or information which in their opinion I should learn, are provided on the web page named **pajak jan uk.htm** (for its version in the HTML language), or the web page named **pajak jan uk.pdf** (for the version of the web page "pajak_jan_uk.pdf" in safe PDF format - which safe PDF versions of further web pages by the author can also be downloaded via links from item #B1 of the web page named **text 11.htm**).

The author's right for the use of **courteous** title of "Professor" stems from the custom that "with professors is like with generals", namely **when someone is once a professor, than he or she courteously remains a professor forever**. In turn the author of this web page was a professor at 4 different universities, i.e. at 3 of them, from 1 September 1992 untill 31 October 1998, as an "Associate Professor" from English-based educational system, while on one university as a (Full) "Professor" (since 1 March 2007 till 31 December 2007 - means at the last place of employment in his professional life).

However, please notice that because of my rather chronic lack of time, I **reluctantly reply to emails which contain JUST time consuming requests**, while simultaneously they document a complete ignorance of their author in the topic area which I am researching. Therefore, if the reader sends a request to me, I suggest to let me know somehow that he or she actually went through the

trouble of reading my web pages and learning what these pages try to say.

#K7. A copy of this web page is also disseminated as a brochure from series [11] in the safe format "PDF":

This web page is also available in the form of a brochure marked [11], which is prepared in "PDF" ("Portable Document Format") - currently considered to be the most safe amongst all internet formats, as normally viruses cannot cling to PDF. This clear brochure is ready both, for printing, as well as for reading from a computer screen. It also has all its green links still active. Thus, if it is read from the computer screen connected to internet, then after clicking onto these green links, the linked web pages and illustrations will open. Unfortunately, because the volume of it is around a double of the volume of web page which this brochure publishes, the memory limitations on a significant number of free servers which I use, do NOT allow to offer it from them (so if it does NOT download from this address, because it is NOT available on this server, then you should click onto any other address from Menu 3, and then check whether in there it is available). In order to open this brochure (and/or download it to own computer), it suffices to either click on the following green link

[explain.pdf](#)

or to open from any totaliztic web site the PDF file named as in the above green link.

If the reader wishes to check, whether some other totaliztic web page which he or she just is studying, is also available in the form of such PDF brochure, then should check whether it is listed amongst links from "part #B" of the web page named text 11.htm. This is because links from there indicate all totaliztic web pages, which are already published as such brochures from series [11] in PDF format. I wish you a fruitful reading!

#K8. Copyrights © 2013 by Dr Jan Pajak:

Copyrights © 2013 by Dr Jan Pajak. All rights reserved. This web page is a report from outcomes of research of the author - only that is written in a popular language (so that it can be understood by readers with non-scientific orientation). Ideas presented on this web page (and also in other publications by the author) are unique for the author's research, and thus from the same angle these ideas were NOT presented by any other researcher. As such, this web page presents ideas which are the intellectual property of the author. Therefore, the content of this web page is the subject to the same laws of intellectual ownership as every other scientific publication. Especially the author reserves for himself the credit-

rights for the scientific discoveries and inventions described on this web page. Therefore, the author reserves that during repeating any idea presented on this web page (i.e. any theory, principle, deduction, interpretation, device, evidence, proof, etc.), the repeating person gives a full credit to the author of this web page, through clearly explaining that the author of a given idea and/or research is Dr Jan Pajak, through indicating the internet address of this web page under which this idea was published, and through mentioning the date of most recent update of this web page (i.e. the date indicated below).

* * *

If you prefer to read in Polish click on the flag below
(Jeśli preferujesz czytanie w języku polskim
kliknij na poniższą flagę)



Date of starting this page: 5 December 2004

Date of the latest updating of this page: 25 March 2013

(Check in "Menu 3" whether there is even a more recent update!)

[counter](#)